

**SH 3200**  
ALUMINIUM SYSTEMS

Shutter System  
Système de volet



*Creativity in progress*

## Since 1982

with the raw material of aluminium and our ideas as inspiration, we work with devotion to continually improve the lives of our clients through the creation of a better, safer and more comfortable environment. This is what we mean at ALUMINCO when we say **creativity in progress!**

## Depuis 1982

c'est votre confort et sécurité qui nous inspire!  
Notre mission principale est de créer.  
Les produits de demain et d'offrir a nos clients, une ambiance méritante!  
**creativity in progress!**





## A distinctive aluminium industry

ALUMINCO represents the first company in the field, which since its foundation in 1982, initiated a new generation of innovative products of cast aluminium in traditional designs, complying with the current architectural and constructional needs.

Today it has been developed into a completely vertical aluminium industry, probably unique in Greece that processes aluminium in three ways:

- Extrusion - with a production capacity of 13.000 tones of profile per year
- Doors & panels - with a production capacity of 70.000 panels per year
- Foundry - with a production capacity of 1.000 tones per year

In ALUMINCO's production center, which is extended into 30.000 sq.m in Inofyta Viotia, 40 km from Athens, the company has integrated aluminium process units, electrostatic powder coatings, montage, finishing and packaging of the products which produces and delivers finished, ready for use.

With integrated solutions for the professional constructor

Today, among the architectural and constructional solutions, based on aluminium, that ALUMINCO offers, are included:

- Aluminium Profile Systems
- Aluminium Panels
- Main entrance doors
- Railing systems
- Outdoor living systems

And outstanding corporate strategy

- **Restless, innovative spirit**

Continuously focusing into research and development of new, improved products and systems which can fully comply with the quality, aesthetics and functionality standards, of the most demanding and fast developing markets of the world. Besides, it's not an accidental fact that ALUMINCO's export activity covers 60

countries and 5 continents.

- **Persistence in quality**

With production processes certified by the ISO 9001 & ISO 9014  
With dyeing processes based on the QUALICOAT specifications and extra Seaside Class process.

With aluminium systems and railings certified by international institutes and organizations, such as IFT Rosenheim, Bureau Veritas, TUV, INSTITUTO GIORDANO, ICC, EKANAL.

- **Great flexibility**

To conform to customers' special needs and requirements. Although ALUMINCO produces a great range of products and covers almost every architectural and constructional application, it is always available to design and produce customized products and solutions in order to satisfy even the most demanding ones!



## Une marque de confiance

**ALUMINCO** depuis plus que trente-cinq ans, est reconnue pour le développement des produits et systèmes de menuiseries aluminium, innovants et durables.

Il y a quelques années, ALUMINCO a pu renforcer son dynamisme économique et sa présence sur le marché national et international, étant présent a soixante pays dans les cinq continents. De nos jours, elle a été évoluée en une industrie d'aluminium complètement verticale, probablement unique en Europe qui transforme l'aluminium en trois chaînes de production:

- L'extrusion –capacité de production de 13.000 tonnes des profils par année.
- Portes & panneaux –capacité de production de 70.000 panneaux par année.
- Fonderie –capacité de production de 1.000 tonnes per année.

Implantée sur le Zone Industriel a Oinofyta , et 30.000 m<sup>2</sup> de superficie , a 40 Km d' Athènes, la société a intégré les unités de extrusion d'aluminium, des chaînes de laquage vertical et horizontal, boîte de montage et usinage pour la fourniture de produits prêt a la pose.

Avec des solutions intégrées pour les fabricants professionnels. Aujourd'hui, parmi les solutions architecturales et de construction, ALUMINCO offre,

- Systèmes de menuiseries aluminium
- Panneaux de portes en aluminium
- Porte d'entrée
- Garde-corps & Garde-corps vitrées.
- Systèmes d' ombrage

Stratégie de l' entreprise – restez a l' écoute de notre réseau, offrir tous les bénéfices de notre expertise!

### • Esprit innovante, toujours en quête de meilleure performance!

Concentrant dans la recherche et le développement des solutions intelligentes, systèmes qui offrent une liberté architecturale.

Parce que le bâtiment doit être source de créativité et d' inspiration pour les architectes, Aluminco allie la technologie et confort pour que l' homme puisse construire facilement des bâtiments performants, esthétiques et agréables a vivre.

### • Objectif, dédié à la qualité

Avec des procédés de production certifiés par ISO 9001 & ISO 9014.

Avec les procédés de laquage certifiés selon spécifications QUALICOAT et Seaside Class, procès supplémentaire.

Systèmes d'aluminium et garde-corps certifié par instituts et organisations internationaux, comme IFT Rosenheim, Bureau Veritas, TUV, INSTITUTO GIORDANO, ICC, EKANAL.

### • Grand flexibilité

Pour se conformer aux exigences et besoins les plus sophistiqués de clients.

Enfin, la capacité de Aluminco a traiter de projets spéciaux d' envergure est illustrée par une présentation de différentes réalisations, dans plusieurs pays du monde.

Un grand nombre de projets prestigieux sont habillés soit avec des systèmes Aluminco, soit avec des solutions personnalisés!





# SH 3200

Shutter system  
Le système

Shutter System

The new Shutter system “SH 3200” reflects the current trends for passive solar shading suitable for residential buildings.

Le nouveau SH du système vantail 3200 reflète les tendances actuelles de protection solaire, formant une excellente solution pour l'équipement de la maison.

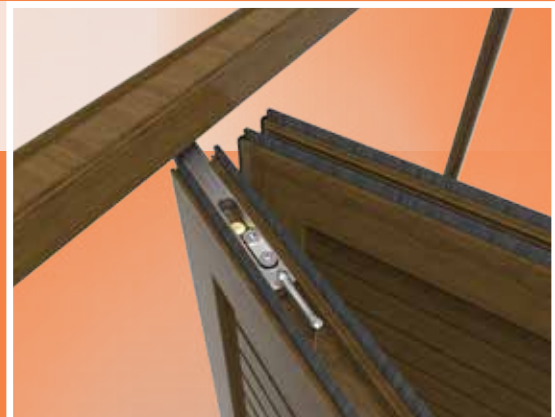

# SH 3200

Shutter System

## Shutter system Le système

The Shutter system SH 3200 stands for the numerous of different structures and typologies that integrates while the inspired design offers high quality constructions with incomparable functionality.

It is thus an external shading system which is installed with both conventional typologies in collaboration with opening windows, as well as an independent structure while its best advantages is that it accepts the entire range of fixed louvers, as well as the system of movable louver of 25 mm.

The SH 3200 demonstrated in practice a pleasant system, extremely friendly and practical to use, unique in its kind.

### Basic Characteristics

- Constructions of opening, sliding and folding shutters systems by using the same sash.
- Use of special rollers for smooth scrolling and alignment of the sash for both folding and sliding system.
- Large variety of opening shutters in all possible typologies (fixed, single-ply, two-ply, four-leaf).
- Accepts fixed louvers, oval and movable louver.
- Movable shading leaves placed on the outer or inner side of the railings and over the railing, ideal for applications on balconies.

Le système vantail SH 3200 représente le nombre de structures différentes et des typologies qui intègre avec le design inspire et offre une construction de haute qualité, la fonctionnalité incomparable.

Ceci est un système d'ombrage externe que peut être installé en typologie classiques en collaboration avec l'ouverture des fenêtres, ainsi que d'une structure indépendante, tandis que ses avantages plus forts est qu'il acceptera toute la gamme de lames fixes, et le système de volet mobile 25 mm.

Le système d'obturation SH 3200 a prouvé dans la pratique un système agréable, extrêmement simple et pratique à utiliser, est unique en son genre.

### Caractéristiques clés

- Utilisation du même volet, donné la possibilité de faire des volets de charnière, de glissement et de l'harmonica.
- Utilisez des rouleaux spéciaux pour le défilement régulier et l'alignement de la feuille suspendue pour le système de l'accordéon et pour le système coulissant.
- Beaucoup d'options pour la fabrication de volets battants dans toutes les typologies possibles (constant, monocouche, à deux plis, à quatre feuilles).
- Accepte persiennes fixes, ovale et les persiennes mobiles.
- Feuilles d'ombrages mobiles placés sur le côté extérieur ou intérieur des grilles et par dessus la rambarde, idéal pour des applications sur les balcons.



Special roller for the alignment of the sash.

Rouleau spécial pour aligner la feuille suspendue.

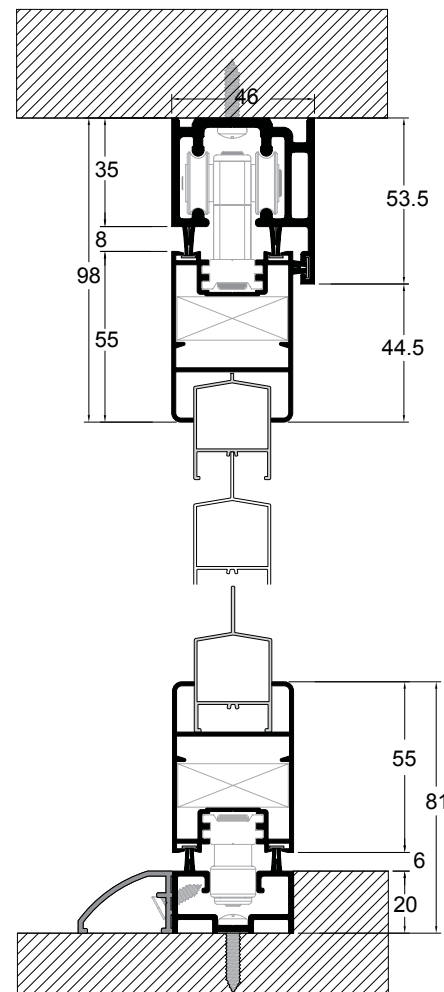

### Technical characteristics | Technical characteristics

Guide width	Frame width	Sash width
39/46 mm	↔ 60 mm	39 mm

### Profile technical characteristics | Profile technical characteristics

Aluminium alloy Alliage d'aluminium	Temper Dureté	thickness Epaisseur de la couche de laquage	Profile thickness Epaisseur profil	Relevant standard Selon la norme
AlMgSi 0,5 (EN AW 6060)	T6	75 µm	1,4-2 mm	EN 12020-2:2008





**SH 3200**  
ALUMINIUM SYSTEMS







Index



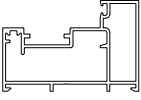

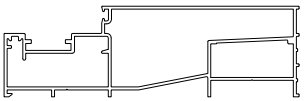
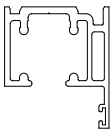
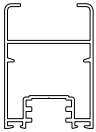

Catalogue Overview / Aperçu du catalogue	11
Profiles 1:1 / Profile 1:1	17
Opening / Ouvrant	27
Accordion / Accordéon	49
Sliding / Coulissant	63
Movable louver / Persienne mobile	71
Shading / Système d'ombre	77
Accessories / Accessoires	85



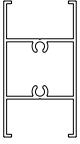



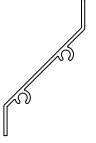
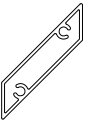







**SH 3200**  
ALUMINIUM SYSTEMS

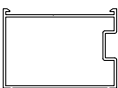
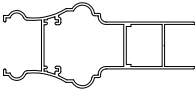



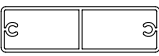

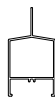

Catalogue Overview  
Aperçu du catalogue

Code Code	Shape Forme	Weight Poids gr/m	Length Longueur m	Pack Package	Moment of Inertia Moment d'inertie cm <sup>4</sup>		Moment of resistance Moment de resistance cm <sup>3</sup>		Description Description
					lx	ly	Wx	Wy	
3200-101		937	6	2	lx	4.84	Wx	0.22	<b>Frame for shutter</b> Châssis du volet
					ly	14.76	Wy	0.47	
3200-102		538	6	4	lx	1.76	Wx	0.12	<b>Slide frame</b> Châssis latéral
					ly	4.05	Wy	0.21	
3200-103		1103	6	3	lx	6.18	Wx	0.31	<b>Upper sliding rail</b> Rail supérieure de couissant
					ly	8.60	Wy	0.44	
3200-104		516	6	6	lx	0.88	Wx	0.09	<b>Bottom guide</b> Rail bas
					ly	3.61	Wy	0.19	
3200-105		1660	6	2	lx	10.34	Wx	0.51	<b>Additional profile for frame</b> Châssis additionnel du volet
					ly	110.02	Wy	1.65	
3200-106		1447	6	2	lx	10.96	Wx	3.09	<b>Upper folding rail</b> Rail supérieure d' accordéon
					ly	14.89	Wy	5.83	
3200-201		855	6	2	lx	8.96	Wx	0.28	<b>Sash for shutter</b> Vantail pour volet
					ly	7.30	Wy	0.37	
3200-202		629	6	4	lx	2.50	Wx	0.16	<b>Frame-Sash</b> Profil-Vantail
					ly	4.57	Wy	0.23	

Code Code	Shape Forme	Weight Poids gr/m	Length Longueur m	Pack Package	Moment of Inertia Moment d'inertie cm <sup>4</sup>		Moment of resistance Moment de resistance cm <sup>3</sup>		Description Description
					lx	ly	Wx	Wy	
3200-401		737	6	3	lx	4.44	Wx	0.28	<b>Transom for profile 3200-201</b> Séparation pour profil 3200-201
					ly	7.09	Wy	0.24	
3200-402		1018	6	2	lx	6.89	Wx	0.43	<b>Bottom rail for profile 3200-201</b> Profil de remplissage 3200-201
					ly	35.02	Wy	0.70	
3200-403		513	6	6	lx	0.57	Wx	0.05	<b>Transom profile</b> Séparation
					ly	3.81	Wy	0.19	
3200-601		502	6	5	lx	1.19	Wx	0.12	<b>Mullion profile</b> Poteau
					ly	3.10	Wy	0.16	
3200-621		358	6	5	lx	3.01	Wx	0.10	<b>Fixed louver</b> Lame fixe
					ly	1.99	Wy	0.11	
3200-622		525	6	5	lx	3.66	Wx	0.14	<b>Fixed louver</b> Lame fixe
					ly	2.65	Wy	0.15	
3200-623		430	6	10	lx	1.92	Wx	0.11	<b>Fixed louver</b> Lame fixe
					ly	1.71	Wy	0.10	
3200-624		531	6	5	lx	1.00	Wx	0.10	<b>Fixed louver</b> Lame fixe
					ly	3.09	Wy	0.17	

Code Code	Shape Forme	Weight Poids gr/m	Length Longueur m	Pack Package	Moment of Inertia Moment d'inertie cm <sup>4</sup>		Moment of resistance Moment de resistance cm <sup>3</sup>		Description Description
					lx	ly	Wx	Wy	
3200-901		201	6	10	lx	-	Wx	-	<b>Additional profile for bottom rail</b>  Profilé supplémentaire
					ly	-	Wy	-	
3200-902		197	6	10	lx	-	Wx	-	<b>Rebate profile</b>  Profilé d'étanchéité du vantail
					ly	-	Wy	-	
3200-903		151	6	10	lx	-	Wx	-	<b>Cover for sash</b>  Capuchon de vantail
					ly	-	Wy	-	
3200-904		244	6	10	lx	-	Wx	-	<b>Side guide for fixed louver</b>  Rail lateral pour lame fixe
					ly	-	Wy	-	
3200-905		151	6	10	lx	-	Wx	-	<b>Cover for transom profile 3200-403</b>  Capuchon de séparation 3200-403
					ly	-	Wy	-	
3200-906		435	6	10	lx	-	Wx	-	<b>Side guide for fixed louver</b>  Rail lateral pour persienne fixe
					ly	-	Wy	-	
3200-907		767	6	4	lx	9.58	Wx	3.65	<b>Additional frame for quad opening</b>  Châssis additionnel
					ly	13.28	Wy	4.24	
3200-908		1134	6	4	lx	33.82	Wx	6.39	<b>Profile for panel</b>  Profil pour panneaux
					ly	7.59	Wy	3.35	

Code Code	Shape Forme	Weight Poids gr/m	Length Longueur m	Pack Package	Moment of Inertia Moment d'inertie cm <sup>4</sup>		Moment of resistance Moment de resistance cm <sup>3</sup>		Description Description
					lx	ly	Wx	Wy	
3200-909		276	6	10	lx	-	Wx	-	<b>Additional for bottom rail</b>  Supplement de rail bas
					ly	-	Wy	-	
038-006		346	6	10	lx	0.20	Wx	0.40	<b>Blind</b>  Lame
					ly	2.94	Wy	1.18	
131-002		812	6	5	lx	1.85	Wx	1.85	<b>Fixed louver</b>  Persienne fixe
					ly	16.66	Wy	4.76	
245-013		590	6	5	lx	10.14	Wx	2.62	<b>Louver</b>  Persienne
					ly	2.24	Wy	1.80	
245-014		433	6	5	lx	7.51	Wx	1.60	<b>Louver</b>  Persienne
					ly	1.51	Wy	1.20	
245-021		574	6	5	lx	12.88	Wx	2.39	<b>Louver</b>  Persienne
					ly	1.02	Wy	0.81	
245-023		674	6	4	lx	23.64	Wx	3.65	<b>Louver</b>  Persienne
					ly	1.20	Wy	0.96	
245-026	 <b>NEW</b>	311	6	5	lx	1.67	Wx	0.60	<b>Louver</b>  Persienne
					ly	1.00	Wy	0.80	

Code Code	Shape Forme	Weight Poids gr/m	Length Longueur m	Pack Package	Moment of inertia Moment d'inertie cm <sup>4</sup>		Moment of resistance Moment de resistance cm <sup>3</sup>		Description Description
					lx	ly	Wx	Wy	
245-027		263	6	5	lx	12.89	Wx	3.48	<b>Louver</b> Persienne
					ly	28.42	Wy	8.16	
410-905		148	6	30	lx	-	Wx	-	<b>Transmission rod</b> Tige de transmission
					ly	-	Wy	-	
510-925		504	6	6	lx	7.56	Wx	2.12	<b>Movable louver</b> Lame mouvante
					ly	0.49	Wy	0.50	
540-801		297	6	10	lx	-	Wx	-	<b>Wall joining profile</b> Couvre joint
					ly	-	Wy	-	
540-901		393	6	2	lx	-	Wx	-	<b>End profile for movable louver</b> Tige de lame mouvante
					ly	-	Wy	-	
540-902		328	6	6	lx	-	Wx	-	<b>Movable louver end profile for sash 25mm</b> Terminal de lame mouvante pour profil 25mm
					ly	-	Wy	-	
540-904		246	6	6	lx	-	Wx	-	<b>End profile for fixed louver</b> Agrafe pour lame
					ly	-	Wy	-	
540-905		143	6	10	lx	-	Wx	-	<b>Clip</b> Capuchon
					ly	-	Wy	-	



**SH 3200**  
ALUMINIUM SYSTEMS

Profiles 1:1  
Profile 1:1

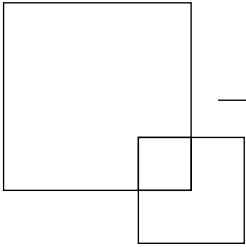

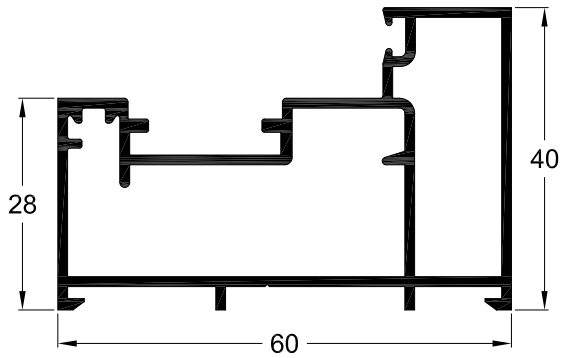

Code	3200-101
Weight   Poids	937 gr/m
Description	Frame for shutter
Description	Châssis du volet

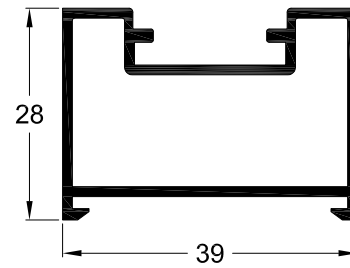

Code	3200-102
Weight   Poids	538 gr/m
Description	Side frame
Description	Châssis latéral

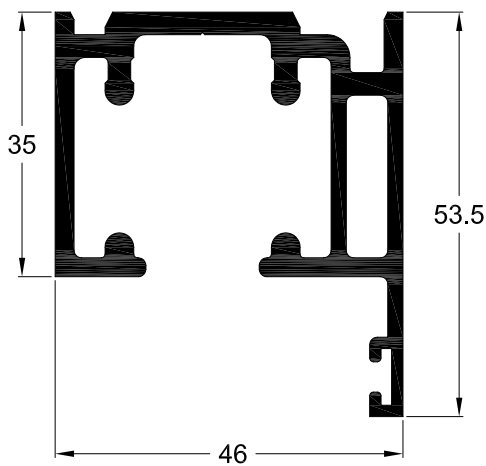

Code	3200-106
Weight   Poids	1447 gr/m
Description	Upper folding rail
Description	Rail supérieure d' accordéon

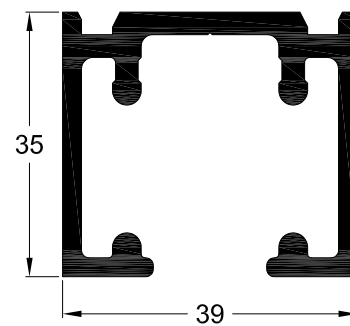

Code	3200-103
Weight   Poids	1103 gr/m
Description	Upper sliding rail
Description	Rail supérieure de coulissant

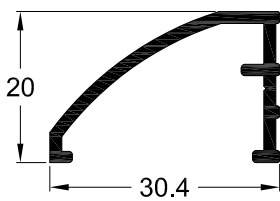

Code	3200-909
Weight   Poids	276 gr/m
Description	Additional for bottom rail
Description	Supplement de rail bas

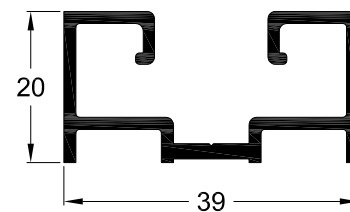

Code	3200-104
Weight   Poids	516 gr/m
Description	Bottom guide
Description	Rail bas

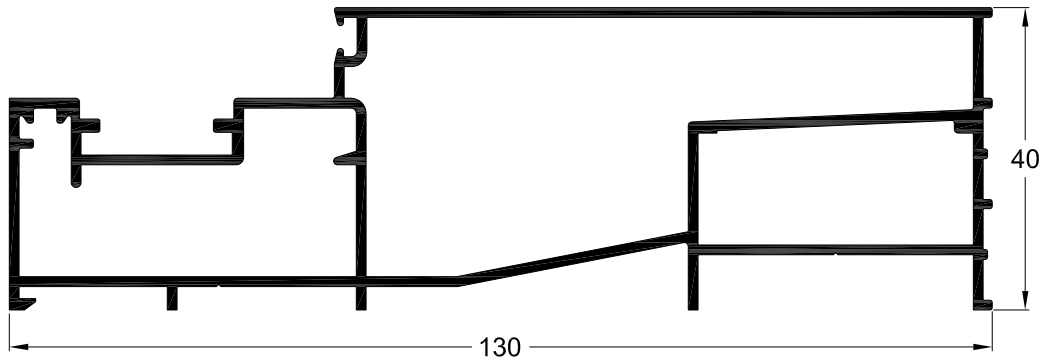

Code	3200-105
Weight   Poids	1660 gr/m
Description	Additional profile for frame
Description	Châssis additionnel du volet

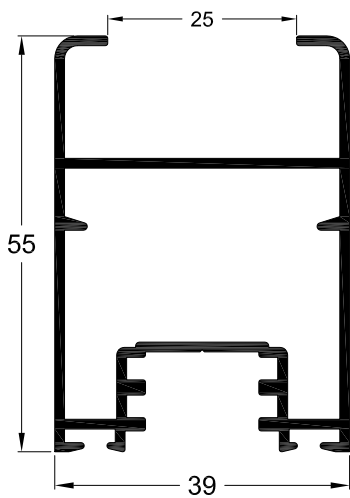

Code	3200-201
Weight   Poids	855 gr/m
Description	Sash for shutter
Description	Vantail pour volet

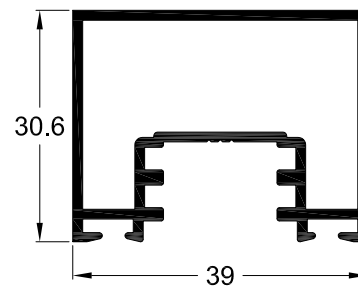

Code	3200-202
Weight   Poids	629 gr/m
Description	Frame - Sash
Description	Profil-Vantail

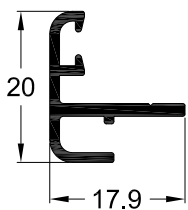

Code	3200-902
Weight   Poids	197 gr/m
Description	Rebate profile
Description	Profile d'étanchéité du vantail

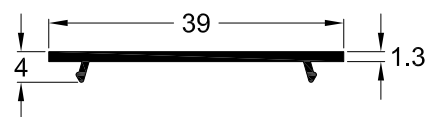

Code	3200-903
Weight   Poids	151 gr/m
Description	Cover for sash
Description	Capuchon de vantail

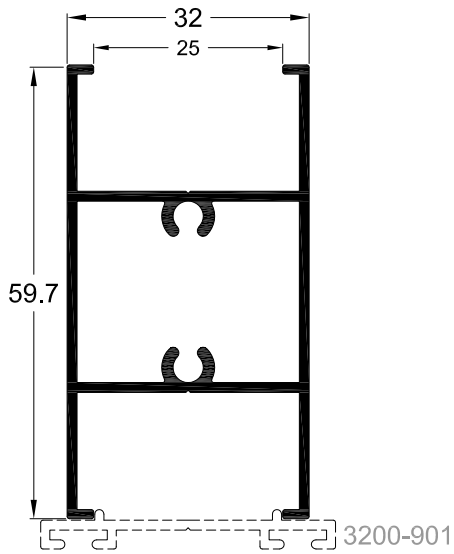

Code	3200-401
Weight   Poids	737 gr/m
Description	Transom profile for 3200-201
Description	Séparation pour profil 3200-201

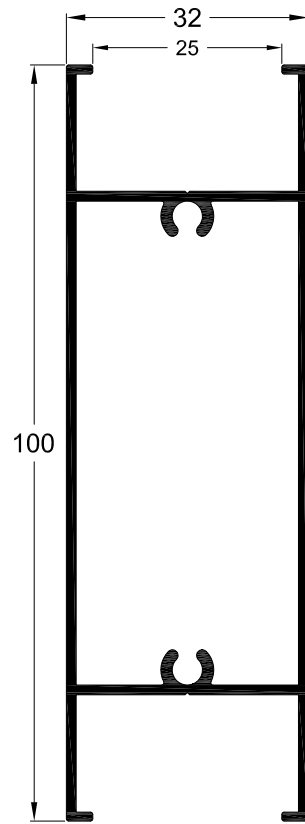

Code	3200-402
Weight   Poids	1018 gr/m
Description	Bottom rail for 3200-201
Description	Profil de remplissage 3200-201

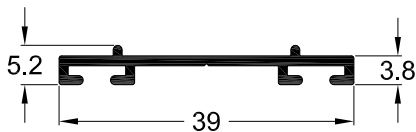

Code	3200-901
Weight   Poids	201 gr/m
Description	Additional profile for bottom rail
Description	Profil supplémentaire

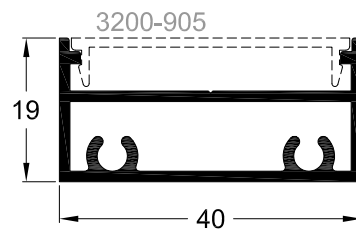

Code	3200-403
Weight   Poids	513 gr/m
Description	Transom profile
Description	Séparation

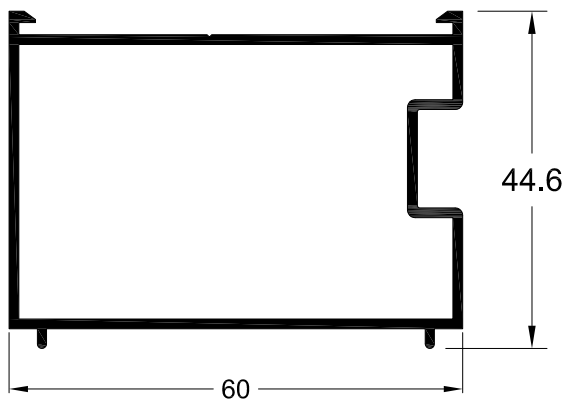

Code	3200-907
Weight   Poids	767 gr/m
Description	Additional frame for quad opening
Description	Châssis additionnel

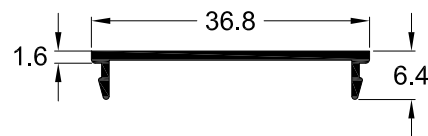

Code	3200-905
Weight   Poids	151 gr/m
Description	Cover for transom 3200-403
Description	Capuchon de séparation 3200-403

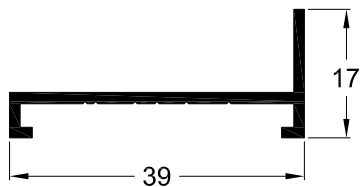

Code	3200-904
Weight   Poids	244 gr/m
Description	Side guide for fixed louver
Description	Rail lateral pour lame fixe

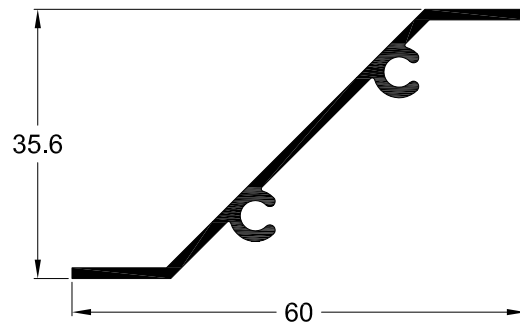

Code	3200-621
Weight   Poids	358 gr/m
Description	Fixed louver
Description	Lame fixe

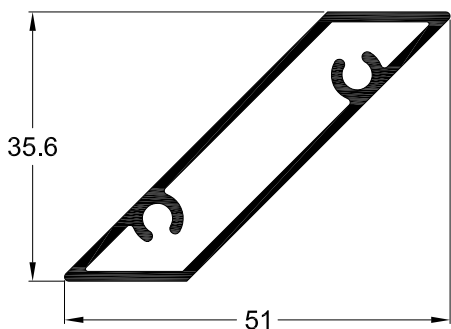

Code	3200-622
Weight   Poids	525 gr/m
Description	Fixed louver
Description	Lame fixe

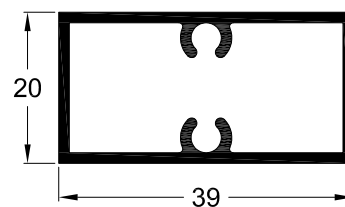

Code	3200-601
Weight   Poids	502 gr/m
Description	Mullion profile
Description	Poteau

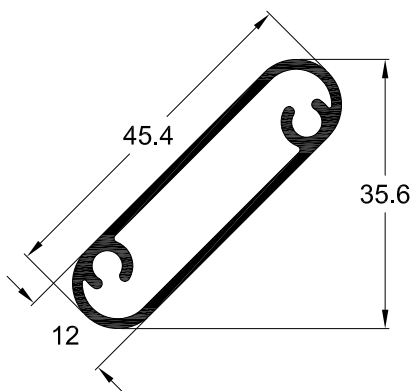

Code	3200-623
Weight   Poids	430 gr/m
Description	Fixed louver
Description	Lame fixe

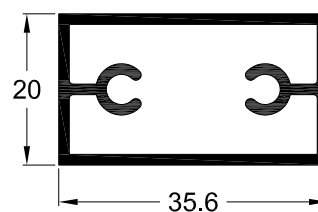

Code	3200-624
Weight   Poids	531 gr/m
Description	Fixed louver
Description	Lame fixe

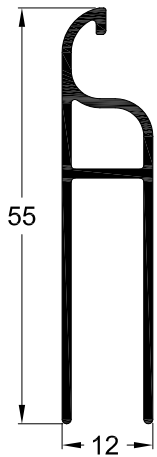

Code	540-901
Weight   Poids	393 gr/m
Description	End profile for movable louver
Description	Tige de lame mouvante

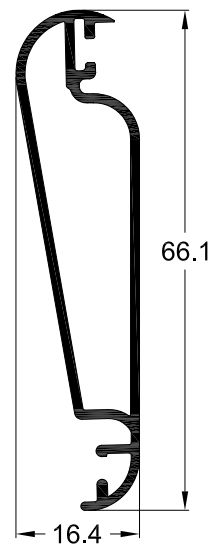

Code	510-925
Weight   Poids	504 gr/m
Description	Movable louver
Description	Lame mouvante

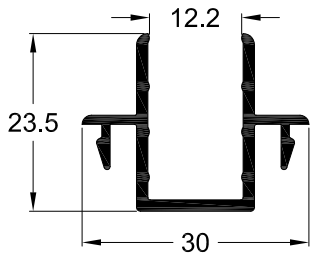

Code	540-902
Weight   Poids	328 gr/m
Description	Movable louver end profile for sash 25mm
Description	Terminal de lame mouvante pour profil 25mm

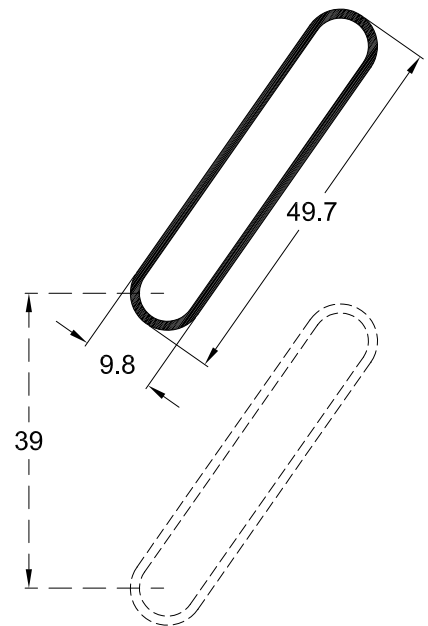

Code	038-006
Weight   Poids	346 gr/m
Description	Blind
Description	Lame

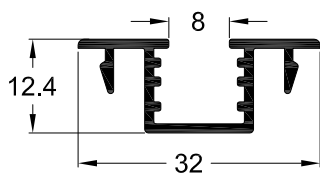

Code	540-904
Weight   Poids	246 gr/m
Description	End profile for fixed louver
Description	Agrafe pour lame

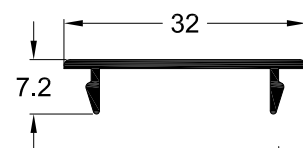

Code	540-905
Weight   Poids	143 gr/m
Description	Clip
Description	Capuchon

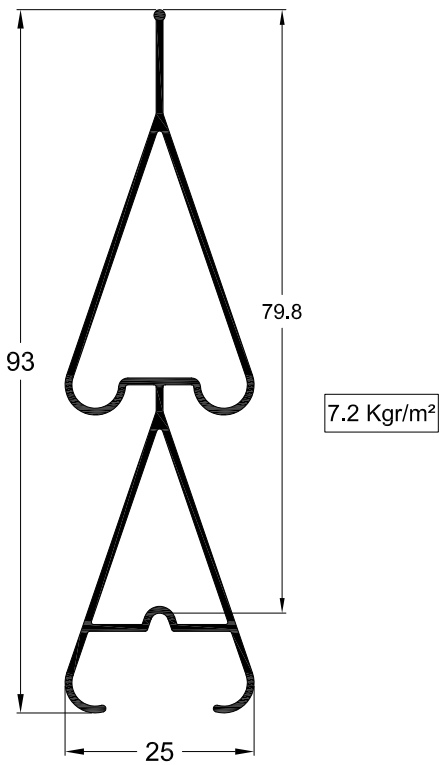

Code	245-021
Weight   Poids	574 gr/m
Description	Double louver
Description	Persienne

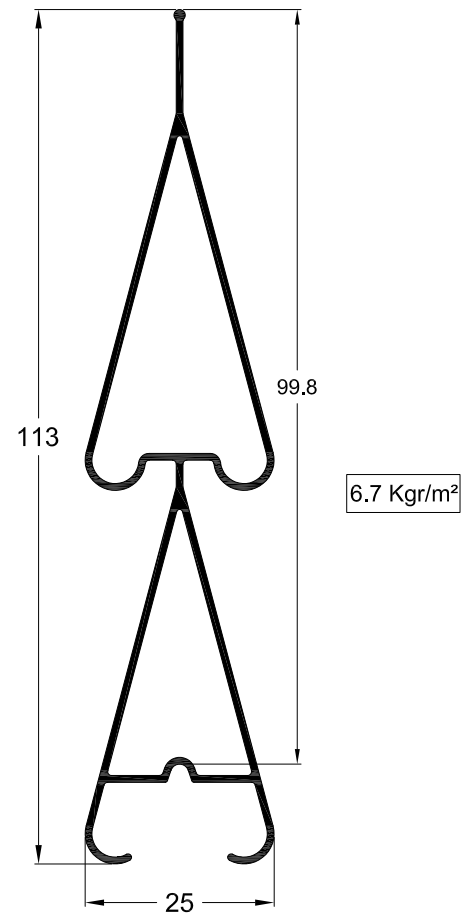

Code	245-023
Weight   Poids	674 gr/m
Description	Double louver
Description	Persienne

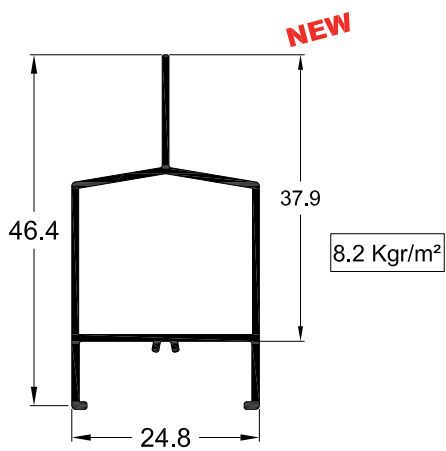

Code	245-026
Weight   Poids	311 gr/m
Description	Louver
Description	Persienne

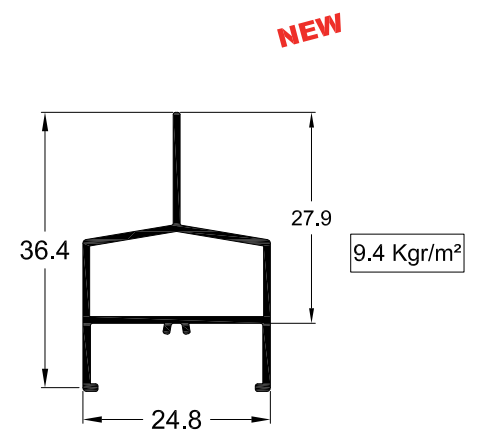

Code	245-027
Weight   Poids	263 gr/m
Description	Louver
Description	Persienne

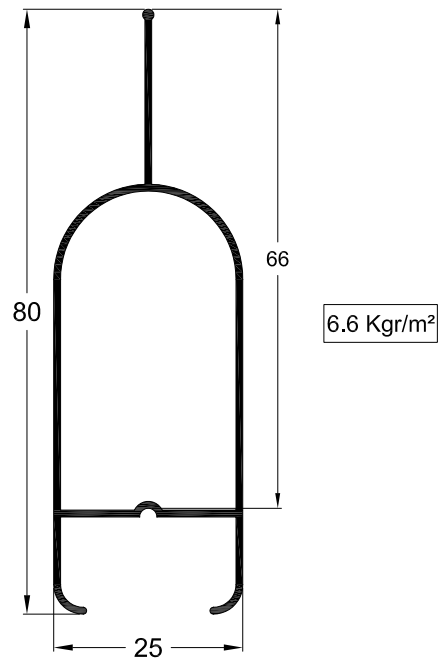

Code	245-014
Weight   Poids	433 gr/m
Description	Louwer
Description	Persienne

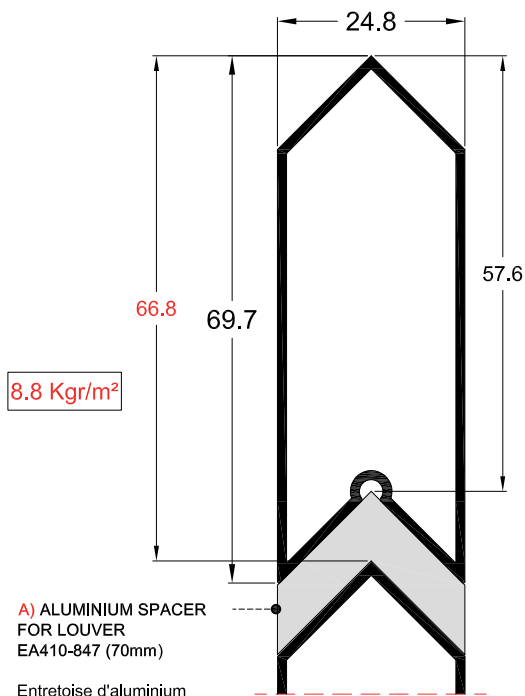

**A) ALUMINIUM SPACER FOR LOUVER**  
EA410-847 (70mm)

Entretroise d'aluminium pour persienne  
EA410-847 (70mm)

**B) ALUMINIUM SPACER FOR LOUVER**  
EA410-848 (120mm)

Entretroise d'aluminium pour persienne  
EA410-848 (120mm)

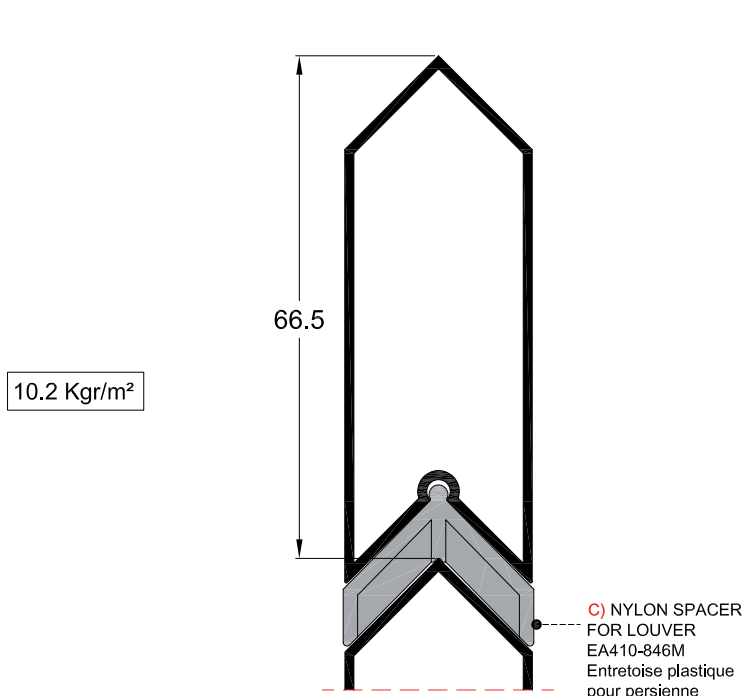

**C) NYLON SPACER FOR LOUVER**  
EA410-846M  
Entretroise plastique pour persienne

Code	245-013
Weight   Poids	590 gr/m
Description	Louwer
Description	Persienne



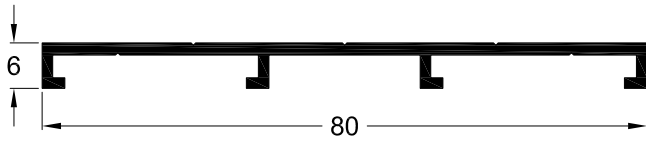

Code	3200-906
Weight   Poids	435 gr/m
Description	Side guide for fixed louver
Description	Rail lateral pour persienne fixe

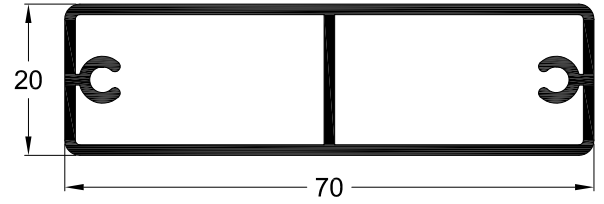

Code	131-002
Weight   Poids	812 gr/m
Description	Fixed louver
Description	Persienne fixe

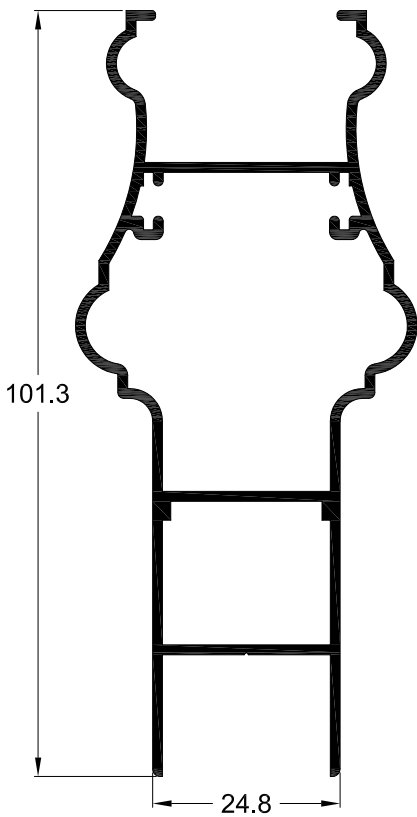

Code	3200-908
Weight   Poids	1134 gr/m
Description	Profile for panel
Description	Profil pour panneaux

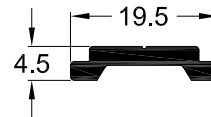

Code	410-905
Weight   Poids	148 gr/m
Description	Transmission rod
Description	Tige de transmission

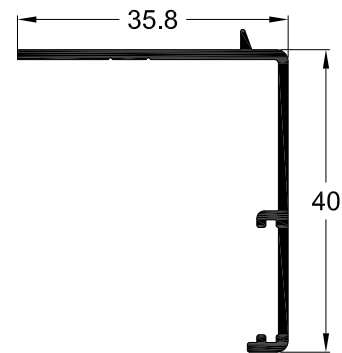

Code	540-801
Weight   Poids	297 gr/m
Description	Wall joining profile
Description	Couvre joint



**SH 3200**  
ALUMINIUM SYSTEMS

Opening  
Ouvrant



## SECTION OF DOUBLE OPENING SHUTTER SASH SECTION D'OUVRANT A DEUX VANTAIL

**FRONT VIEW**  
VUE DE FACE

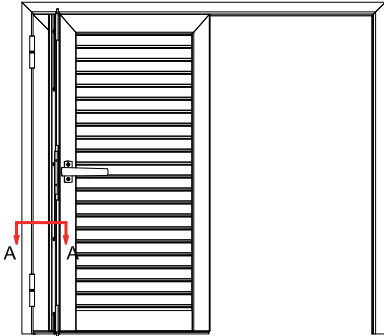

**TOP VIEW**  
VUE DE DESSUS

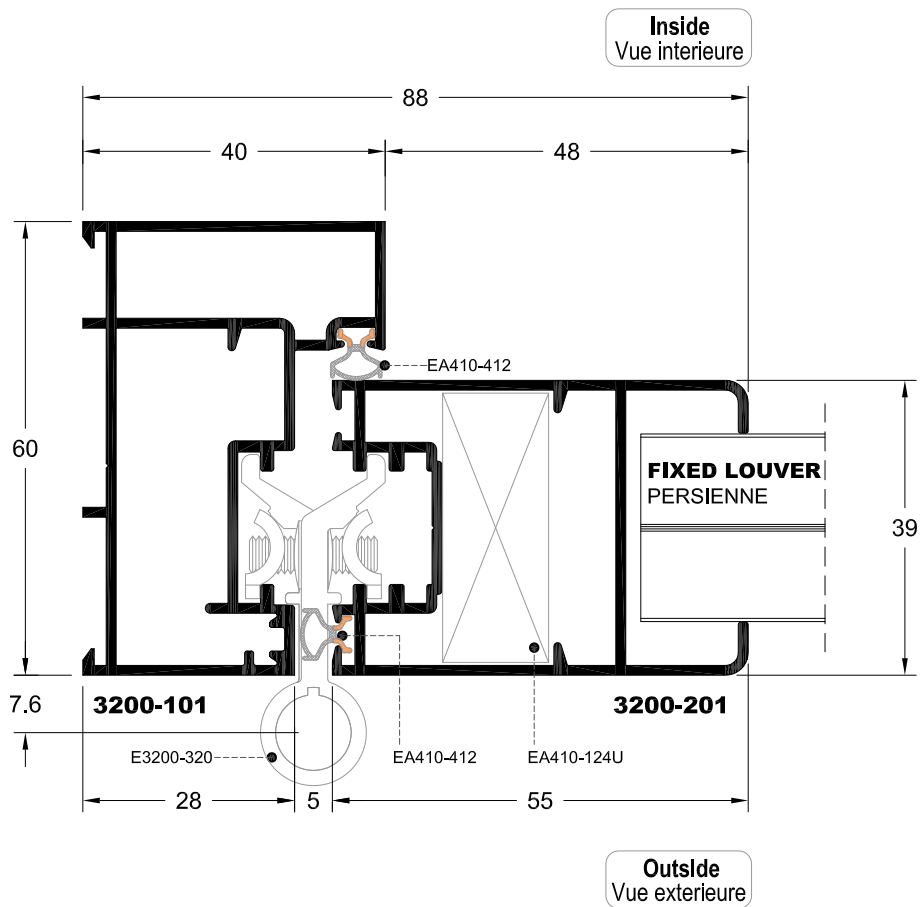
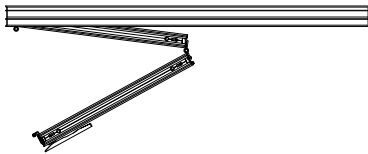

**SECTION OF DOUBLE OPENING SHUTTER SASH**  
**SECTION D'OUVRANT A DEUX VANTAIL**

**FRONT VIEW**  
**VUE DE FACE**

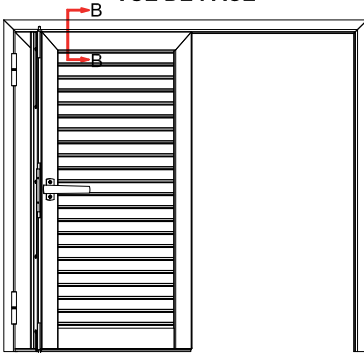

**TOP VIEW**  
**VUE DE DESSUS**

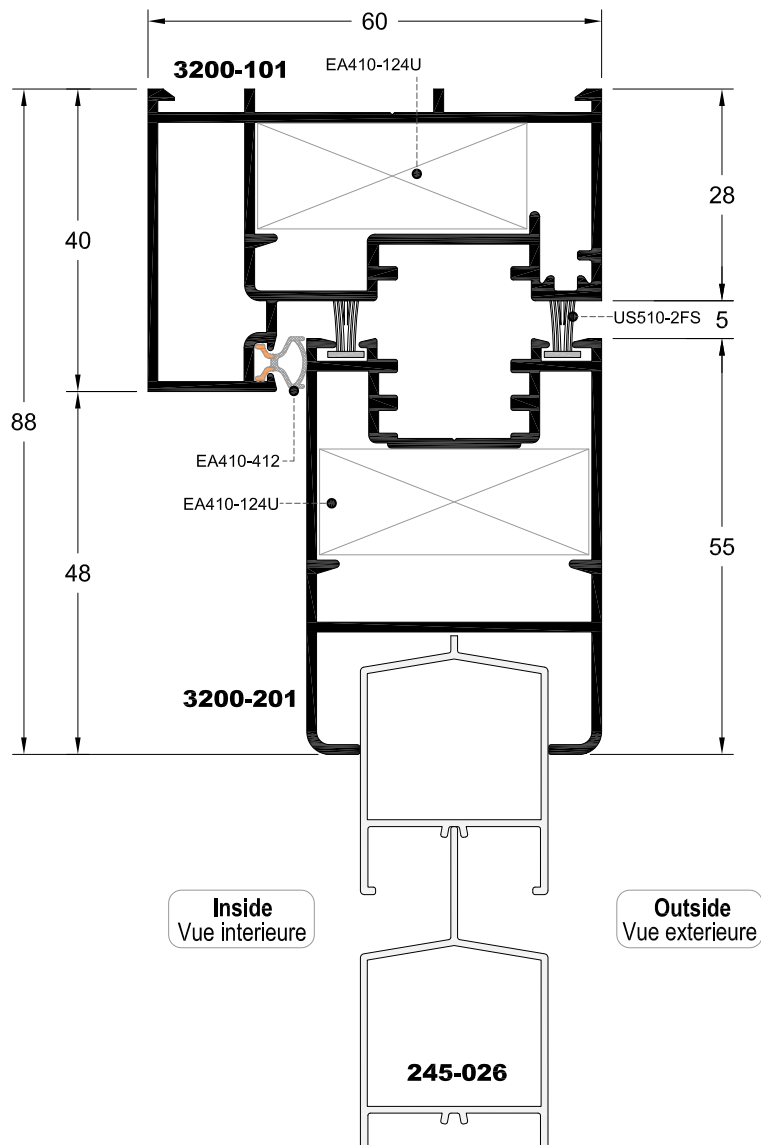
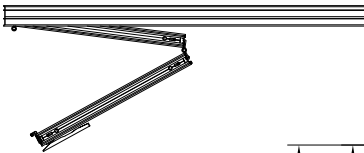

### SECTION OF DOUBLE OPENING SHUTTER SASH

### SECTION D'OUVRANT A DEUX VANTAIL

**FRONT VIEW**  
VUE DE FACE

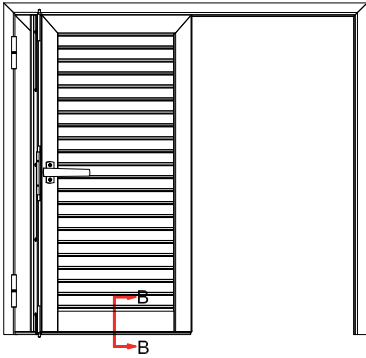

**TOP VIEW**  
VUE DE DESSUS

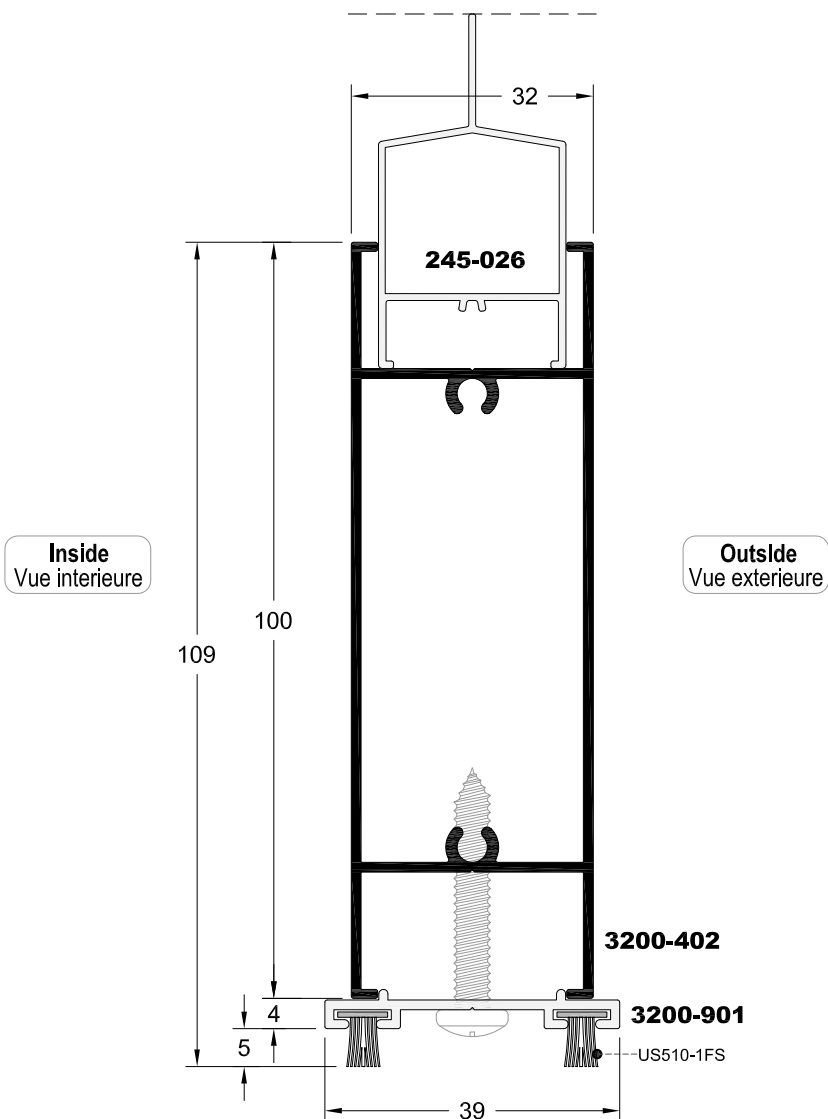
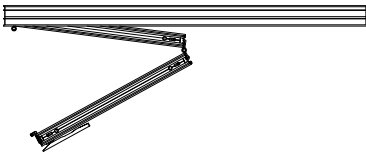

**SECTION OF DOUBLE OPENING SHUTTER SASH**  
**SECTION D'OUVRANT A DEUX VANTAIL**

**FRONT VIEW**  
**VUE DE FACE**

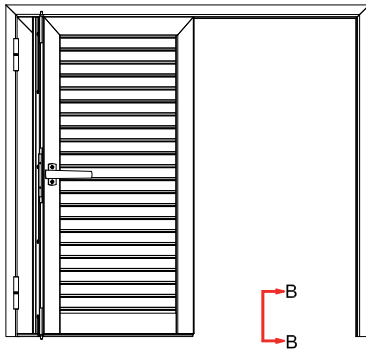

**TOP VIEW**  
**VUE DE DESSUS**

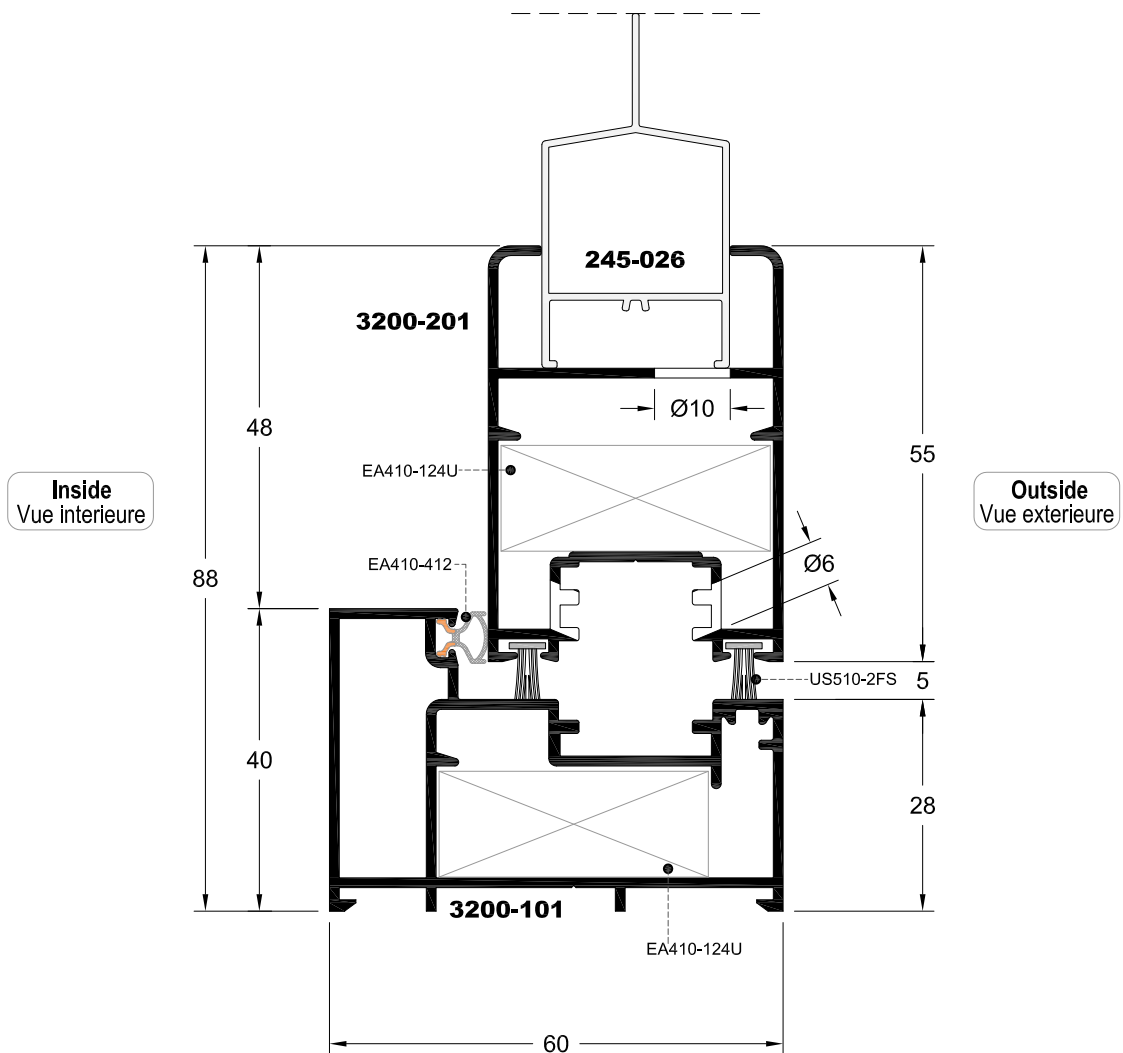
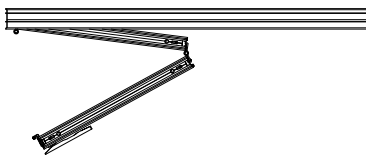

**SECTION OF DOUBLE OPENING SHUTTER SASH**  
**SECTION D'OUVRANT A DEUX VANTAIL**

**FRONT VIEW**  
**VUE DE FACE**

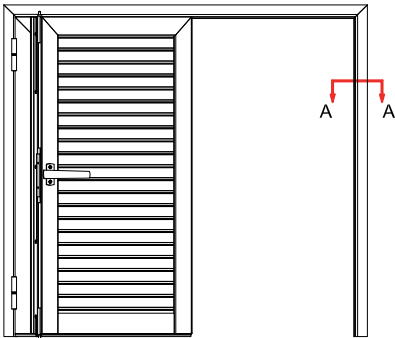

**TOP VIEW**  
**VUE DE DESSUS**

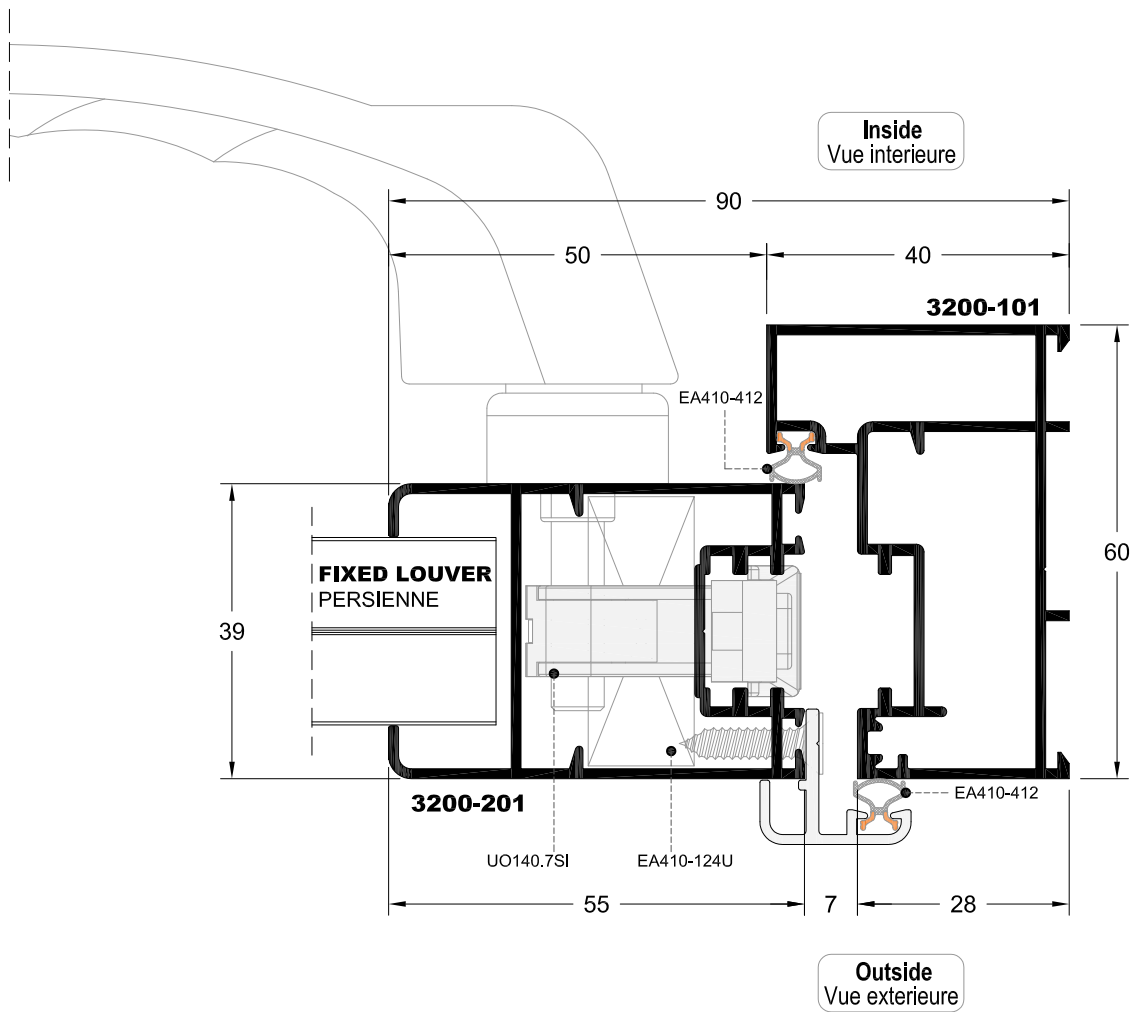
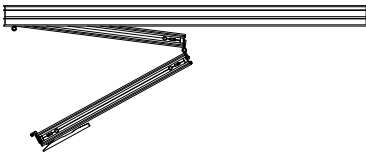



**SECTION OF QUAD OPENING SHUTTER SASH**  
**SECTION D'OUVRANT A QUATRE VANTAIL**

**FRONT VIEW**  
**VUE DE FACE**

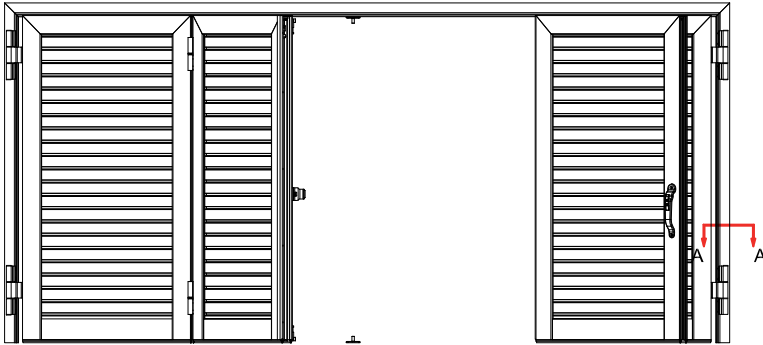

**TOP VIEW**  
**VUE DE DESSUS**

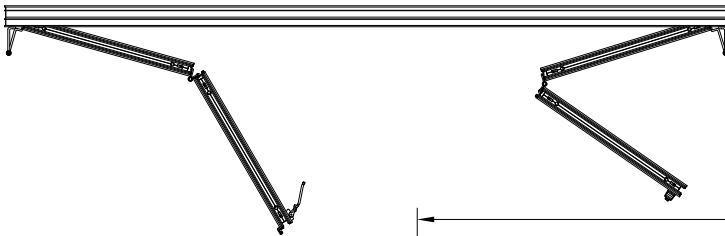

**Inside**  
**Vue interieure**

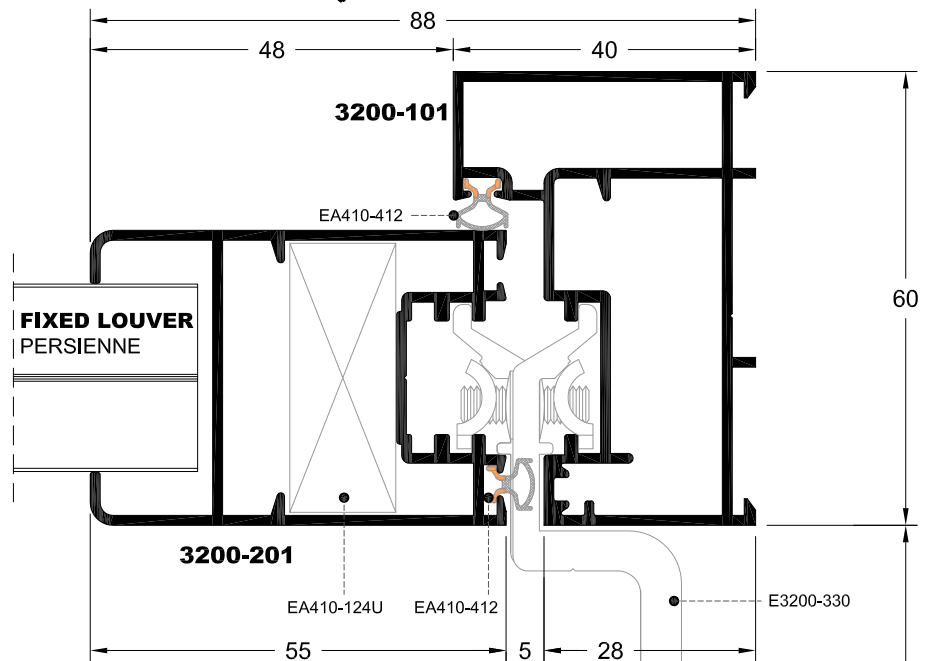

**Outside**  
**Vue exterieure**

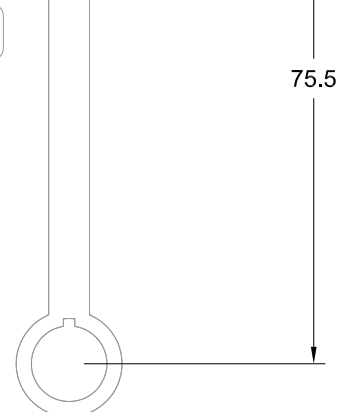

**SECTION OF QUAD OPENING SHUTTER SASH**  
**SECTION D'OUVRANT A QUATRE VANTAIL**

**FRONT VIEW**  
**VUE DE FACE**

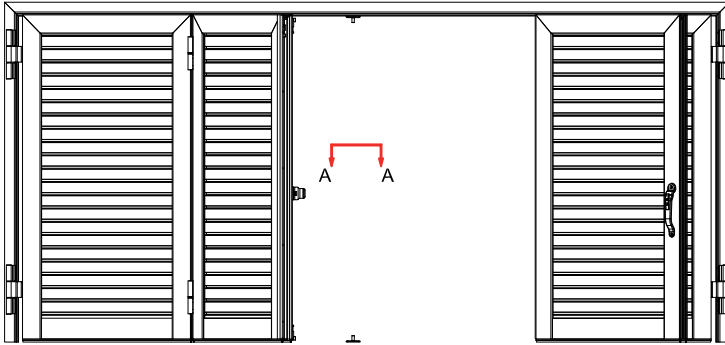

**TOP VIEW**  
**VUE DE DESSUS**

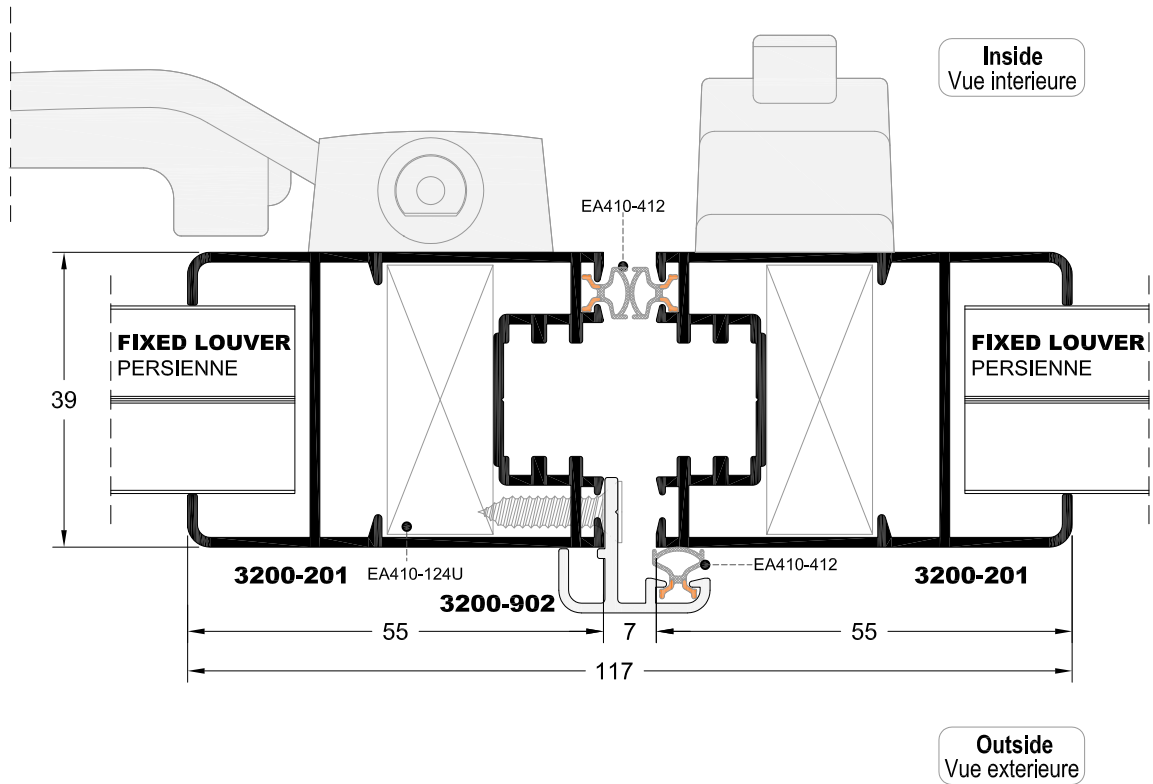
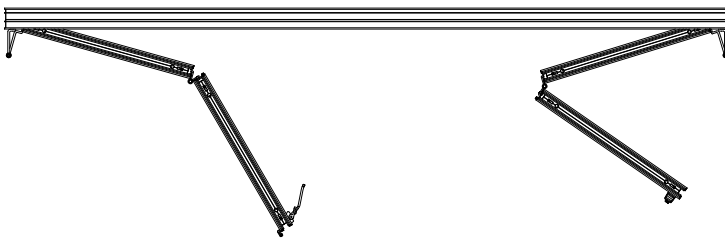

**SECTION OF QUAD OPENING SHUTTER SASH**  
**SECTION D'OUVRANT A QUATRE VANTAIL**

**FRONT VIEW**  
**VUE DE FACE**

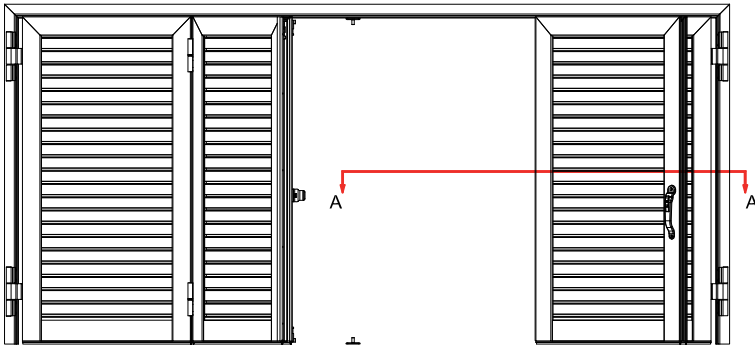

**TOP VIEW**  
**VUE DE DESSUS**

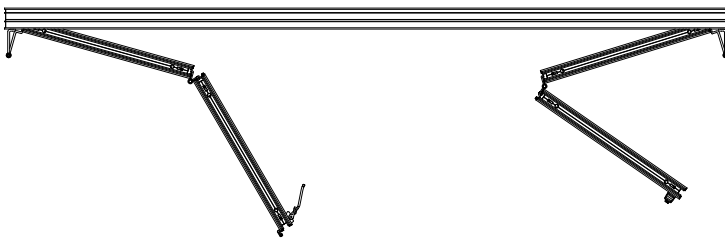

**Inside**  
Vue interieure

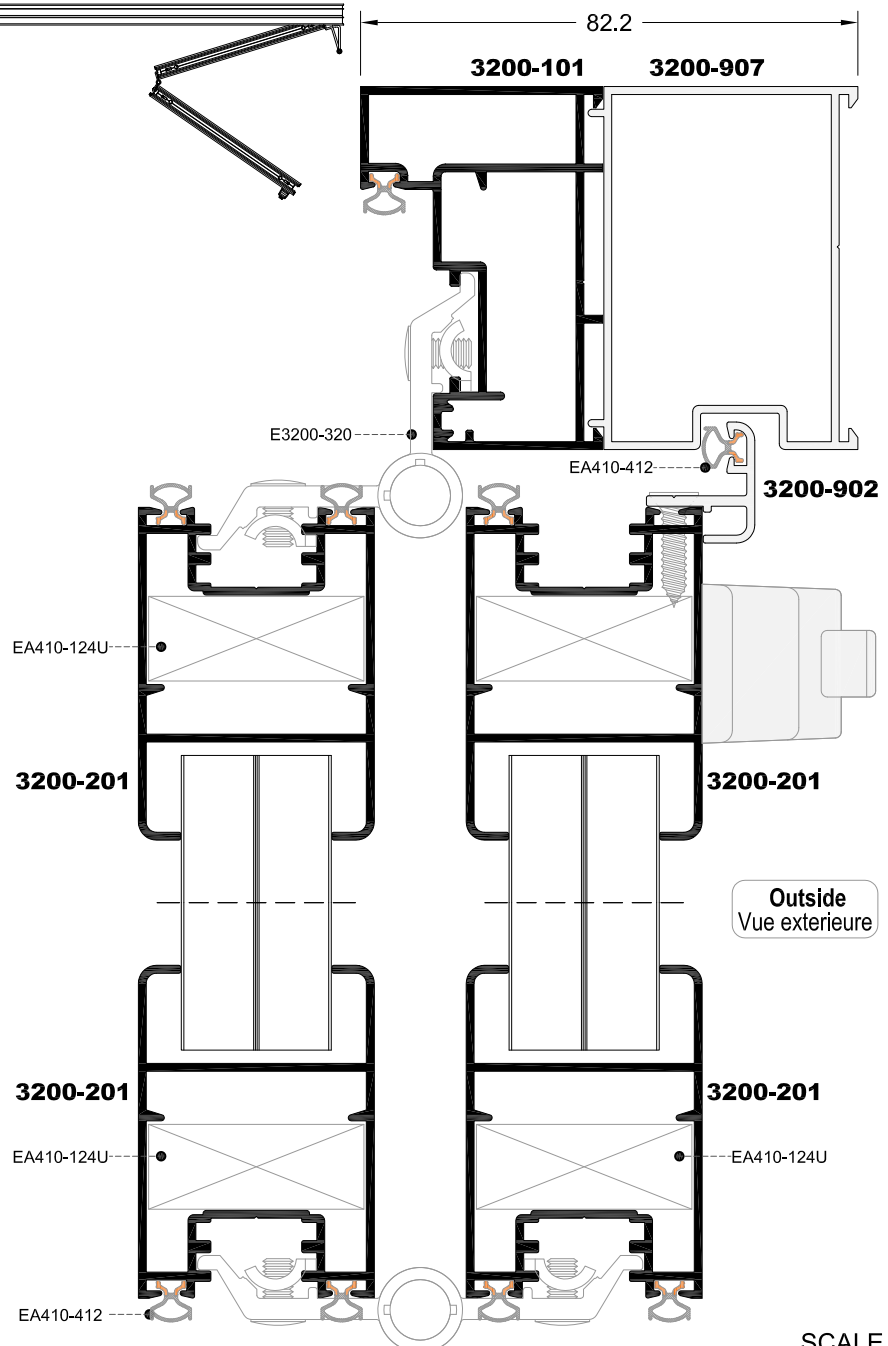

**Outside**  
Vue exterieure

SCALE 1:1.25

**SECTION OF DOUBLE OPENING WITH SHUTTER SASH**

**SECTION D'OUVRANT A DEUX VANTAIL ET VOILETS**

**FRONT VIEW**  
VUE DE FACE

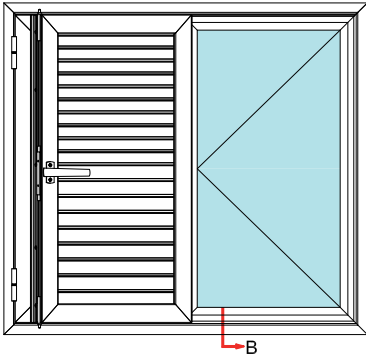

**TOP VIEW**  
VUE DE DESSUS

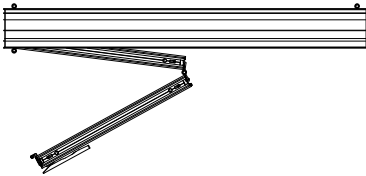

**Inside**  
Vue interieure

**Outside**  
Vue exterieure

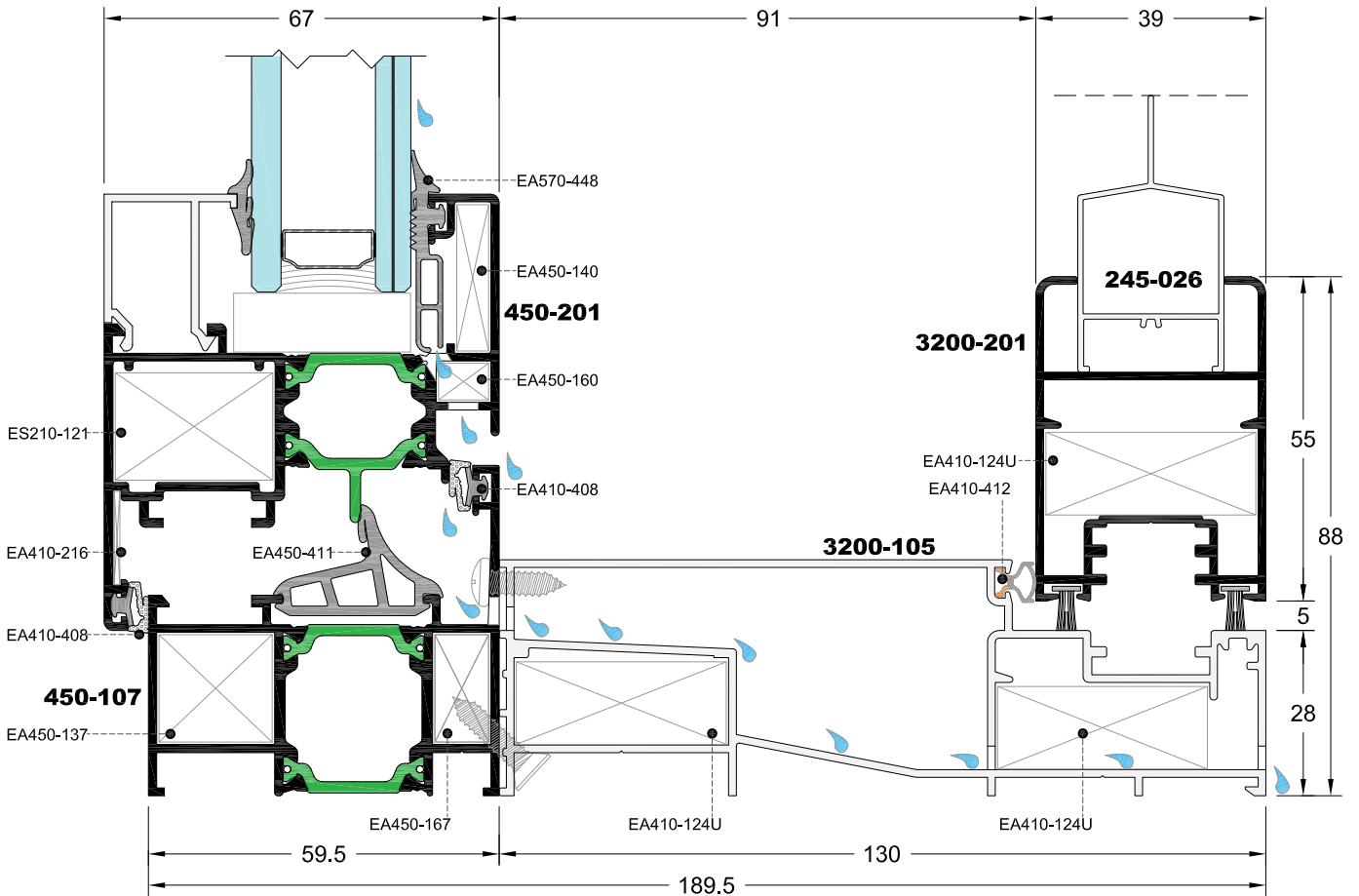

SCALE 1:1.25

**MACHINING ON SASH FOR INSTALLATION OF CORNER JOINT**  
**TRAITEMENT DE VANTAIL POUR L'INSTALLATION DE CORNIÈRE DE JONCTION**

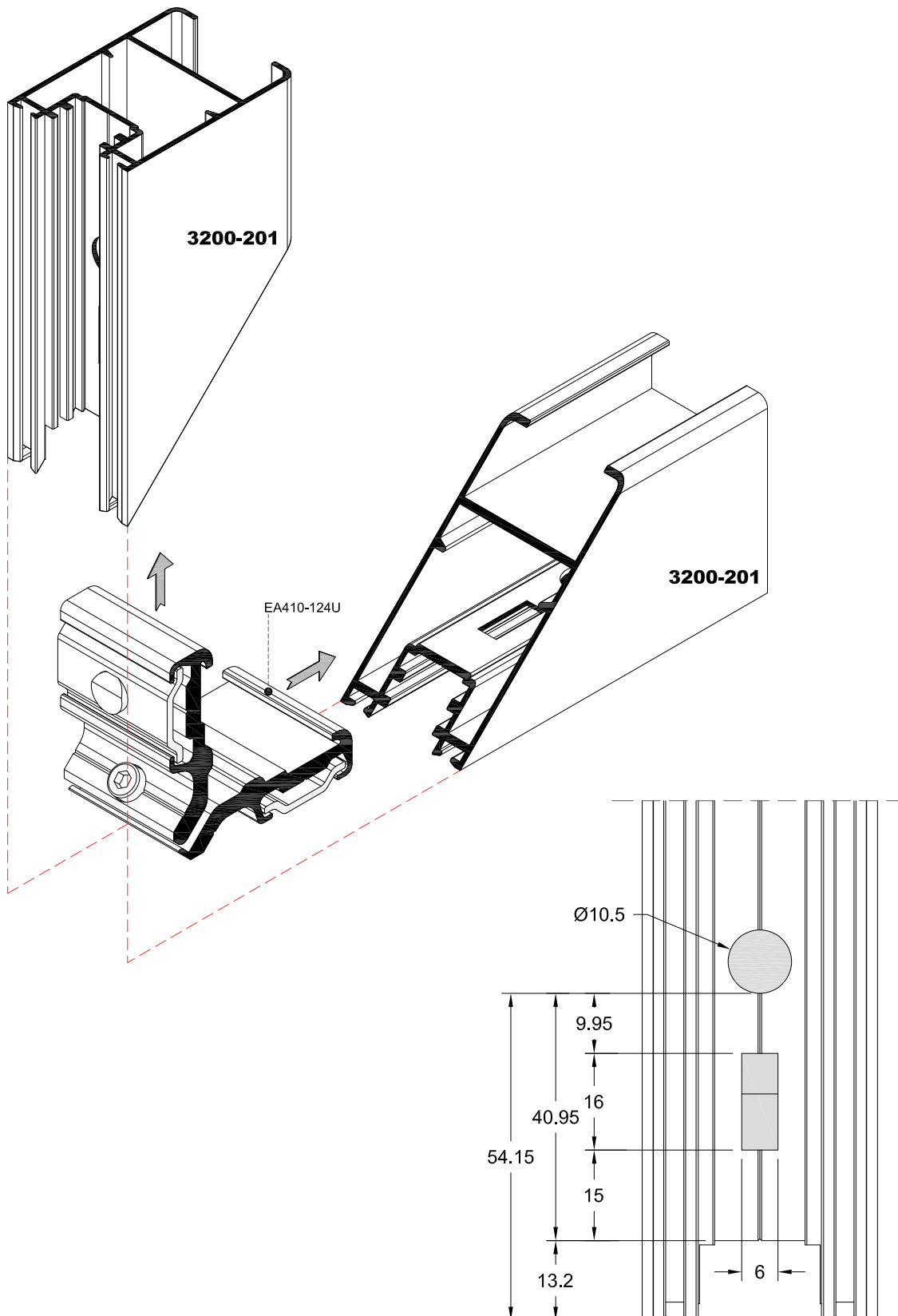

**MACHINING ON SASH FOR LOCK MECHANISM MASTER**  
**TRAITEMENT DE VANTAIL POUR INSTALLATION DE MÉCANISME DE VERROUILLAGE MASTER**

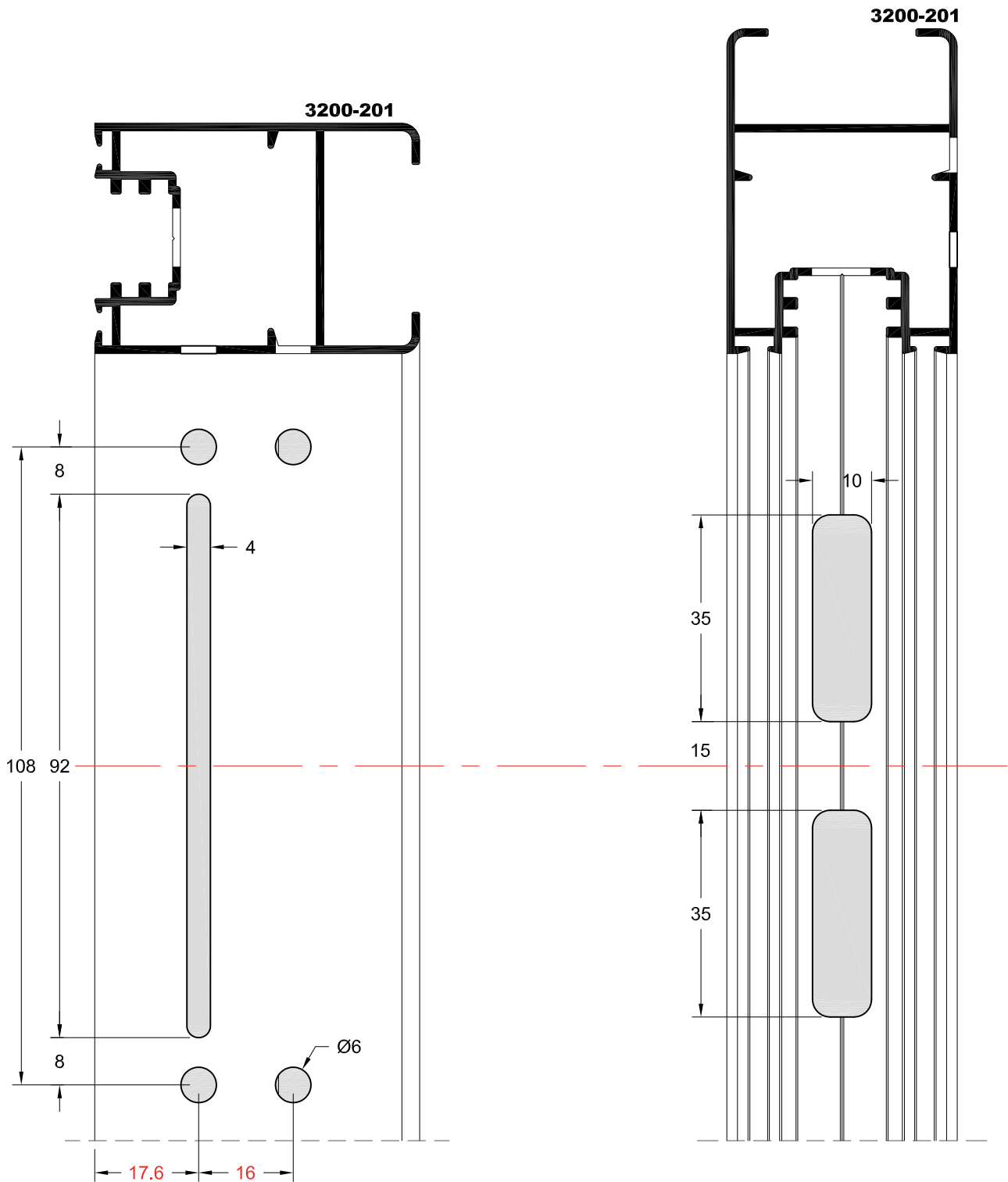

**ACCESSORIES VIEW OF LOCK MECHANISM MASTER**  
**REPRÉSENTATION DE MÉCANISME DE VERROUILLAGE MASTER**

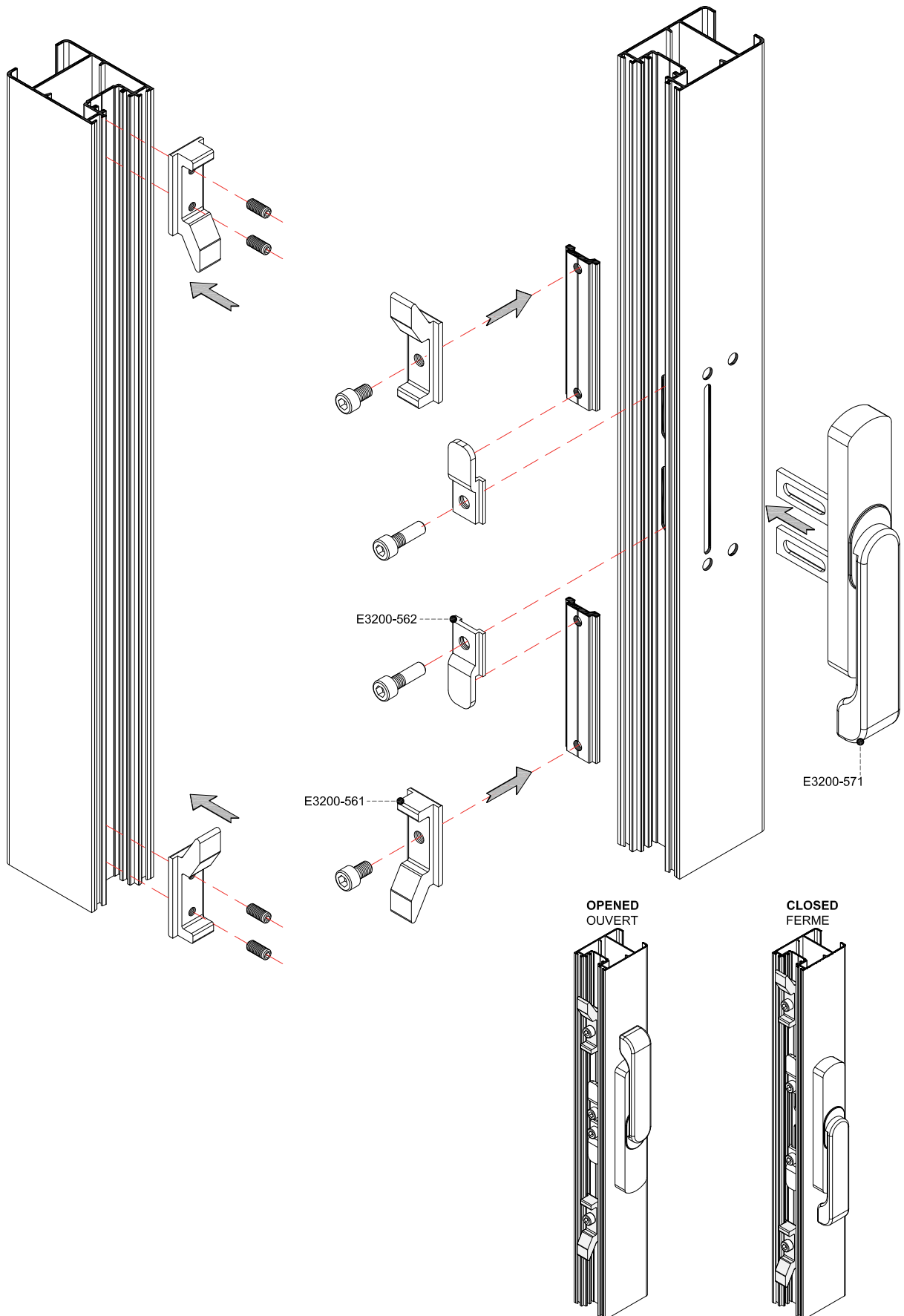

### **MACHINING ON SASH FOR LOCK MECHANISM MASTER**

### **TRAITEMENT DE VANTAIL POUR INSTALLATION DE MÉCANISME DE VERROUILLAGE MASTER**

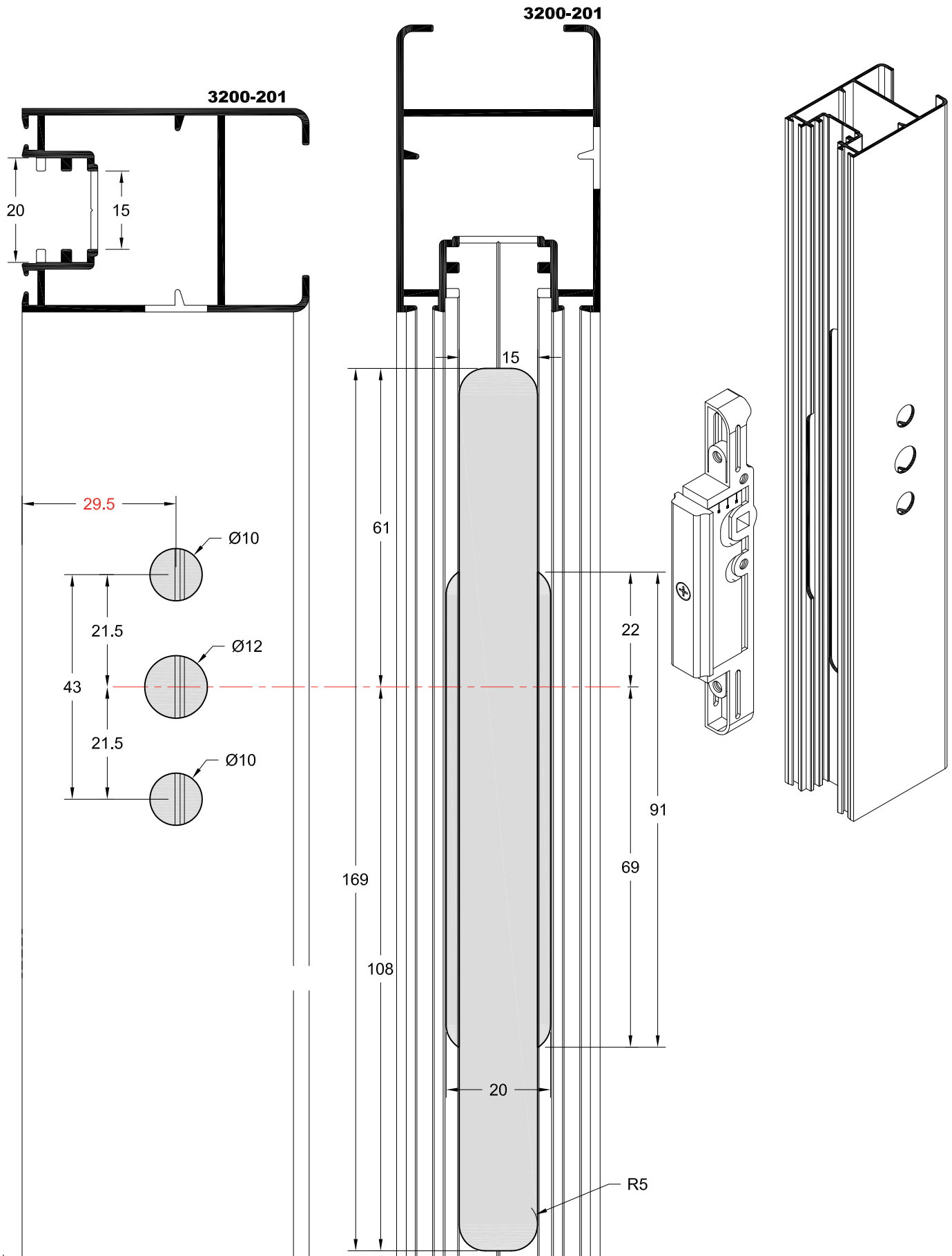



**MACHINING ON SASH FOR LOCK MECHANISM MASTER WITH POP UP LEVER**  
**TRAITEMENT DE VANTAIL POUR INSTALLATION DE MÉCANISME DE VERROUILLAGE MASTER**  
**AVEC LEVIER POP UP**

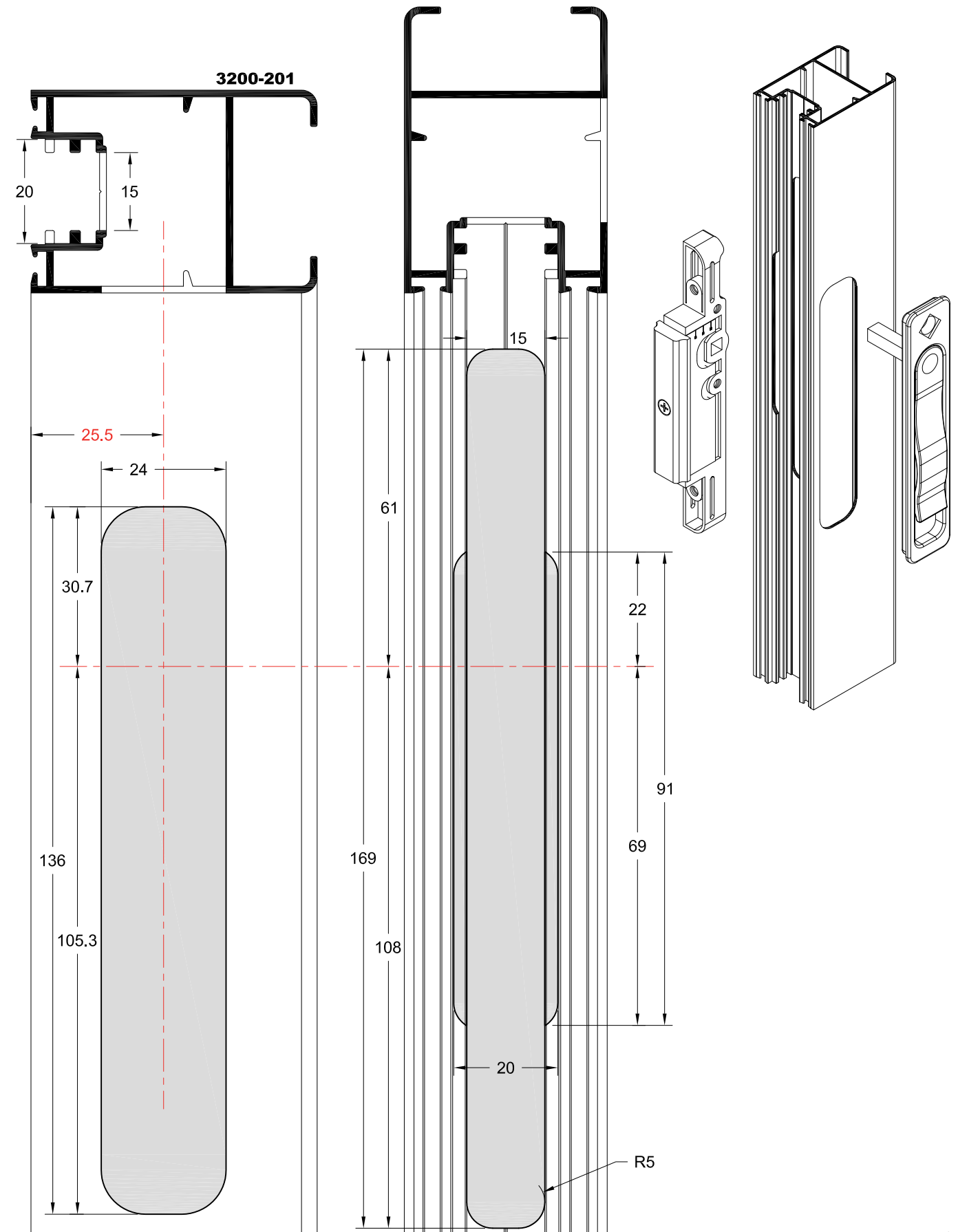

### **MACHINING ON SASH FOR LOCK MECHANISM SIEGENIA**

### **TRAITEMENT DE VANTAIL POUR INSTALLATION DE MÉCANISME DE VERROUILLAGE SIEGENIA**

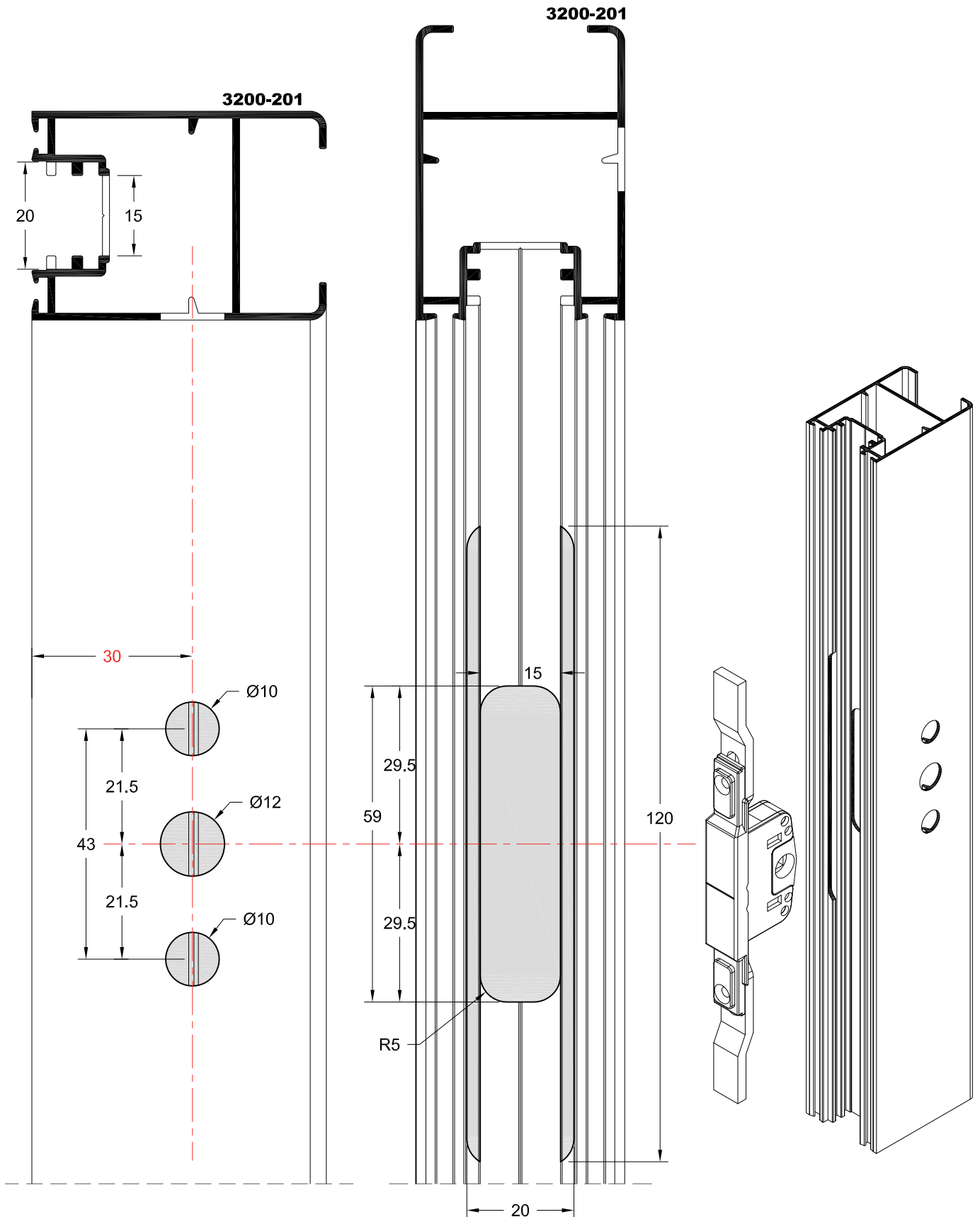

**MACHINING ON TRANSON-BOTTOM RAIL PROFILE**  
**TRAITEMENT DE TRAVERSE ET DU PROFIL DE REMPLISSAGE**

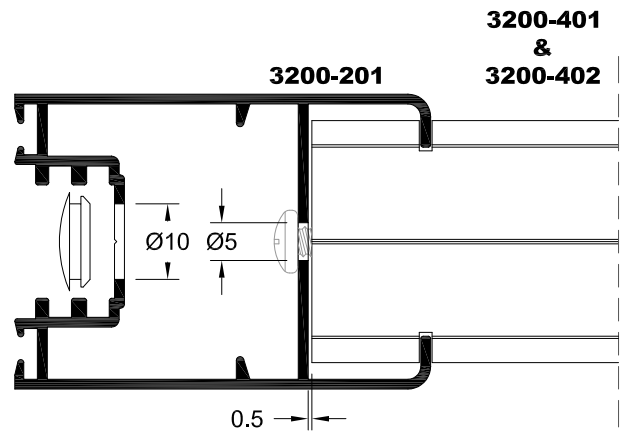
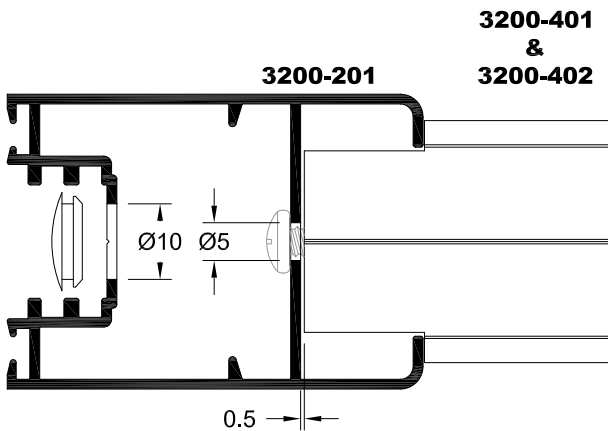
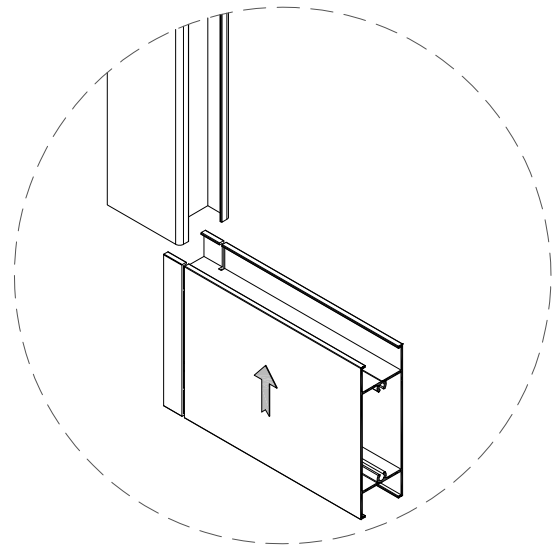
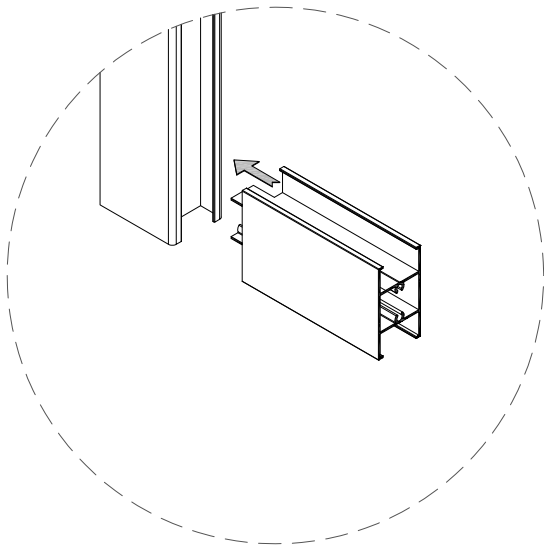

**MACHINING ON ADDITIONAL PROFILE OF BOTTOM RAIL**  
**TRAITEMENT DU PROFIL ADDITIONEL DE REMPLISSAGE**

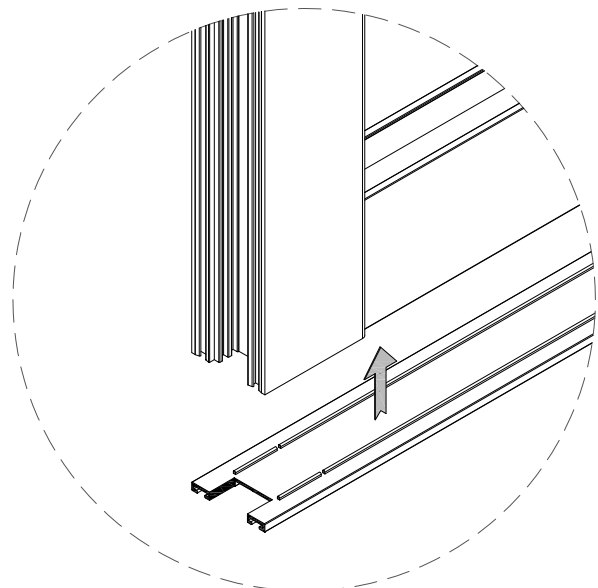
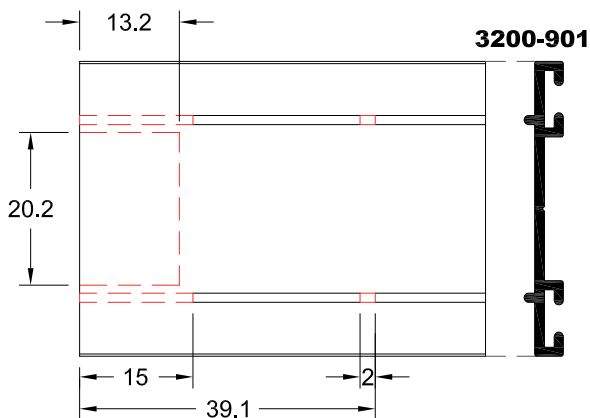

## CONSTRUCTIONS TYPOLOGY TYPLOGIE DE FABRICATION

### Single opening with hinge

Ouvrant avec charnière

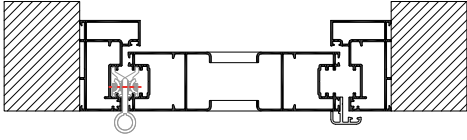

### Single opening with long hinge

Ouvrant avec paumelle

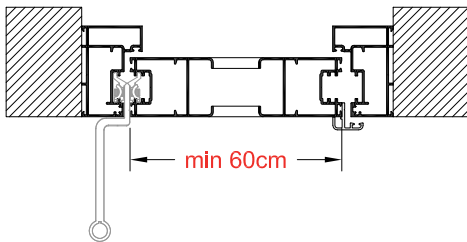

#### **NOTE**

The minimum width for shutter with long hinge is 60cm.

#### **REMARQUE:**

La largeur minimale de la vantail pour la fabrication avec paumelle est de 60cm

### Double opening with hinge

Ouvrant a deux vantaux et avec charnière

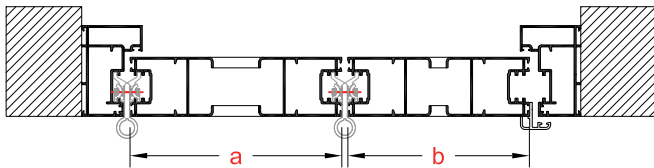

#### **NOTE**

For double opening with hinge, the shutter sash (b) must be cut 20mm shorter than sash (a).

#### **REMARQUE:**

Pour la fabrication d' ouvrant a deux vantaux avec charnière le vantail (b) doit être coupé 20mm moins de la vantail (a)

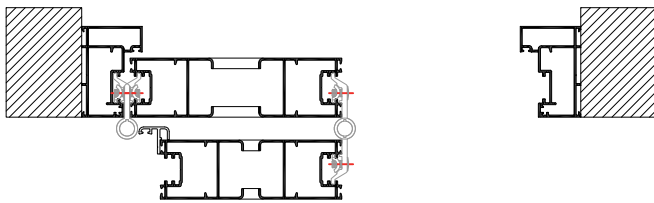

#### **EXAMPLE-EXEMPLE:**

$$a = \{(L-73)/2\text{mm}\} + 10$$

$$b = \{(L-73)/2\text{mm}\} - 10$$

### Double opening with long hinge

Ouvrant a deux vantaux et avec paumelle

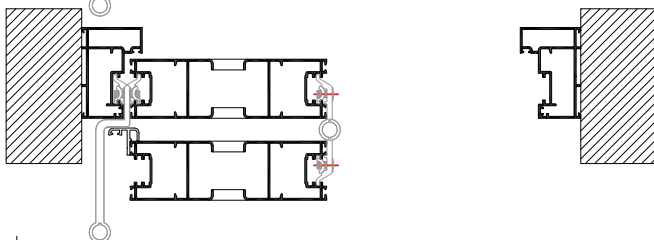
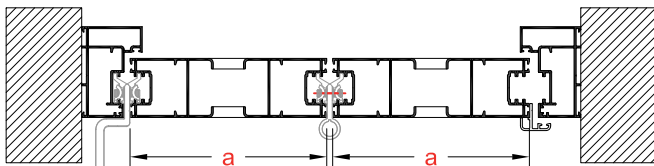

## CONSTRUCTIONS TYPOLOGY TYPLOGIE DE FABRICATION

### Quad opening with hinge and rebate profile inside of construction

Ouvrant a quatre vantaux et avec charnière et meneau a l'interieure de fabrication

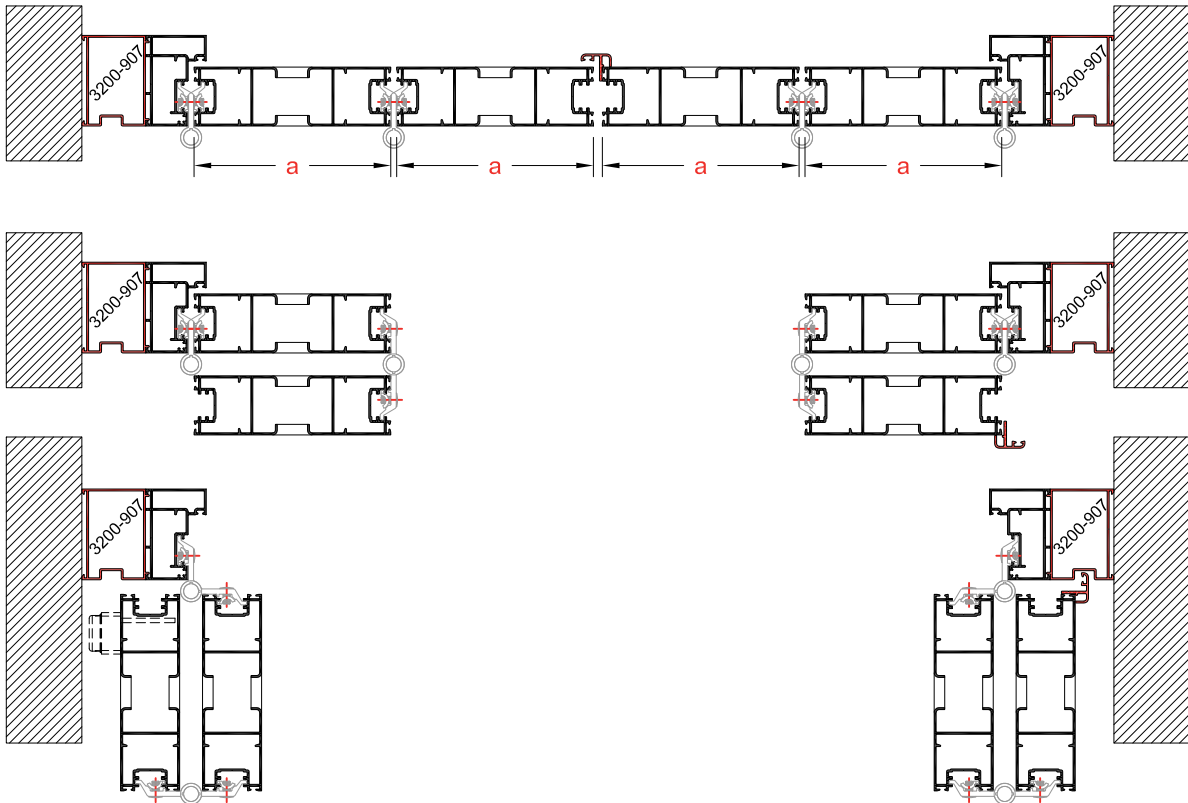

### Quad opening with hinge and rebate profile inside and outside of construction

Ouvrant a quatre vantaux et avec charnière et meneau a l'interieure et exterieure de fabrication

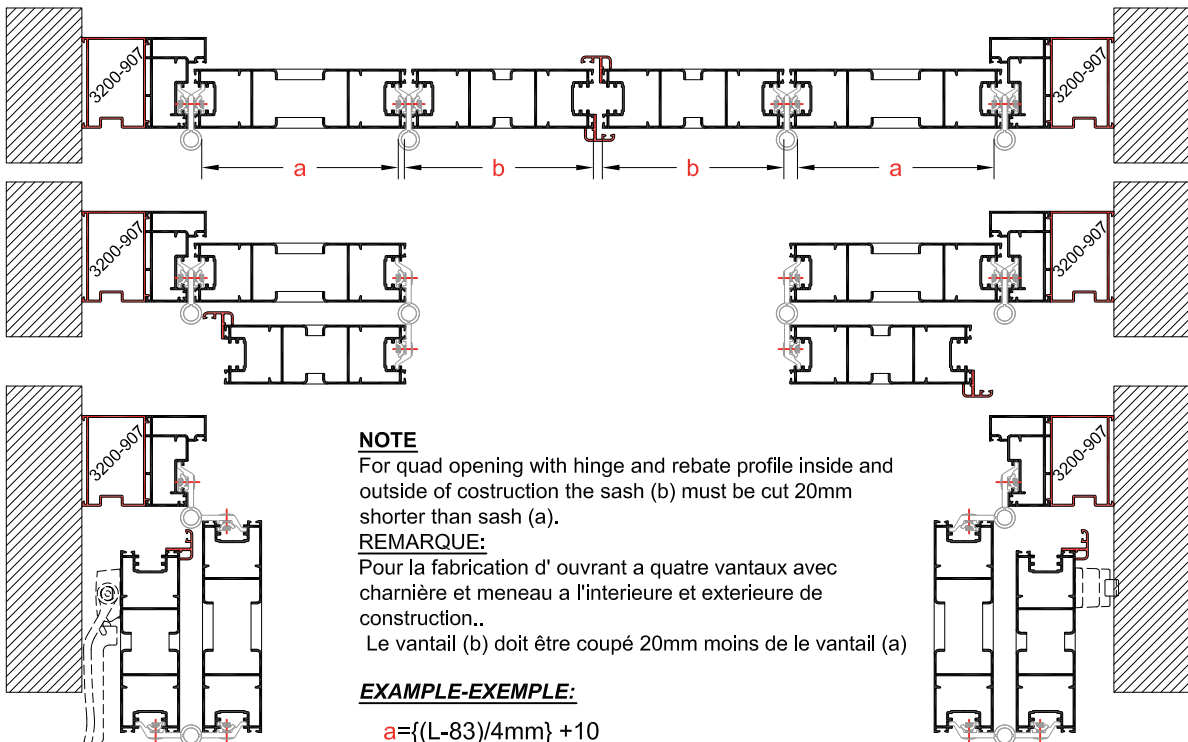

**NOTE**

For quad opening with hinge and rebate profile inside and outside of construction the sash (b) must be cut 20mm shorter than sash (a).

**REMARQUE:**

Pour la fabrication d' ouvrant a quatre vantaux avec charnière et meneau a l'interieure et exterieure de construction..

Le vantail (b) doit être coupé 20mm moins de le vantail (a)

**EXAMPLE-EXEMPLE:**

$$a = \{(L-83)/4\text{mm}\} + 10$$

$$b = \{(L-83)/4\text{mm}\} - 10$$

## **CONSTRUCTIONS TYPOLOGY** **TYPOLOGIE DE FABRICATION**

**Quad opening with long hinge and rebate profile inside and outside of construction**  
Ouvrant a quatre vantaux et avec charnière et meneau a l'interieure et exterieure du profil

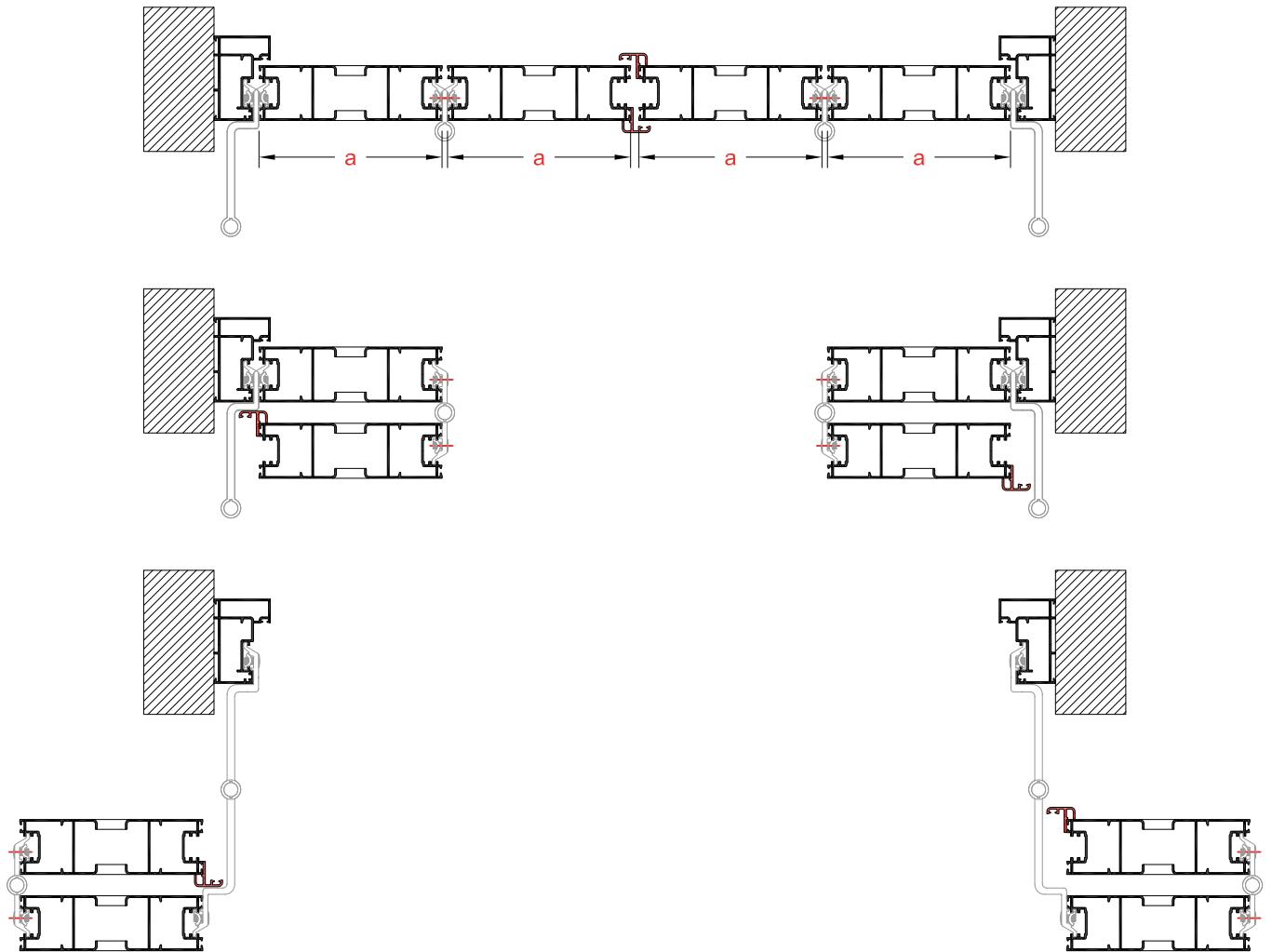

**CUTTING CALCULATIONS FOR OPENING SYSTEM**  
**MESURES DE DECOUPAGE POUR OUVRANT**

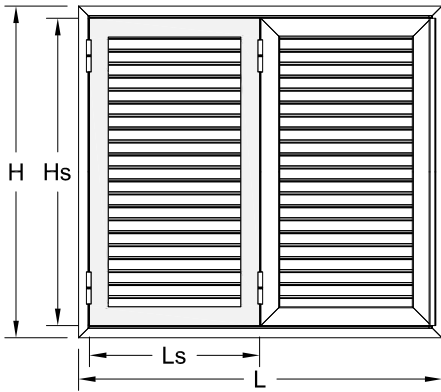

**WITH SASH ALL AROUND**  
**CHÂSSIS A LAME**

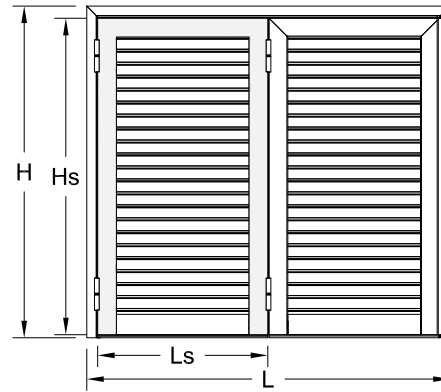

**WITH BOTTOM RAIL**  
**AVEC PROFIL DE REMPLISSAGE**

**Single opening**  
 Ouvrant a une vantail

$H_s = H - 66\text{mm}$

$L_s = L - 68\text{mm}$

**Double opening**  
 Ouvrant a deux vantaux

$H_s = H - 66\text{mm}$

$L_s = L - 73/2\text{mm}$

**Triple opening**  
 Ouvrant a trois vantaux

$H_s = H - 66\text{mm}$

$L_s = L - 78/3\text{mm}$

**Quad opening**  
 Ouvrant a quatre vantaux

$H_s = H - 66\text{mm}$

$L_s = L - 83/4\text{mm}$

**Single opening**  
 Ouvrant a une vantail

$H_s = H - 42\text{mm}$

$L_s = L - 68\text{mm}$

**Double opening**  
 Ouvrant a deux vantaux

$H_s = H - 42\text{mm}$

$L_s = L - 73/2\text{mm}$

**Triple opening**  
 Ouvrant a trois vantaux

$H_s = H - 42\text{mm}$

$L_s = L - 78/3\text{mm}$

**Quad opening**  
 Ouvrant a quatre vantaux

$H_s = H - 42\text{mm}$

$L_s = L - 83/4\text{mm}$

- H = **Frame height**  
Hauteur du fabrication
- L = **Frame width**  
Largeur du fabrication
- Hs= **Sash height**  
Hauteur du vantail
- Ls= **Sash width**  
Largeur du vantail





**SH 3200**  
ALUMINIUM SYSTEMS

Accordion  
Accordéon



### SECTION OF TRIPLE SASH FOLDING SYSTEM SECTION D' ACCORDÉON A TROIS VANTAIL

**FRONT VIEW**  
VUE DE FACE

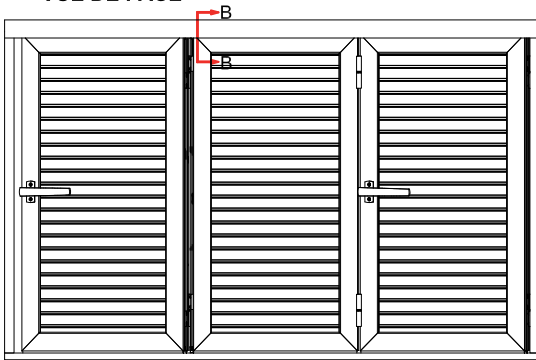

**TOP VIEW**  
VUE DE DESSUS

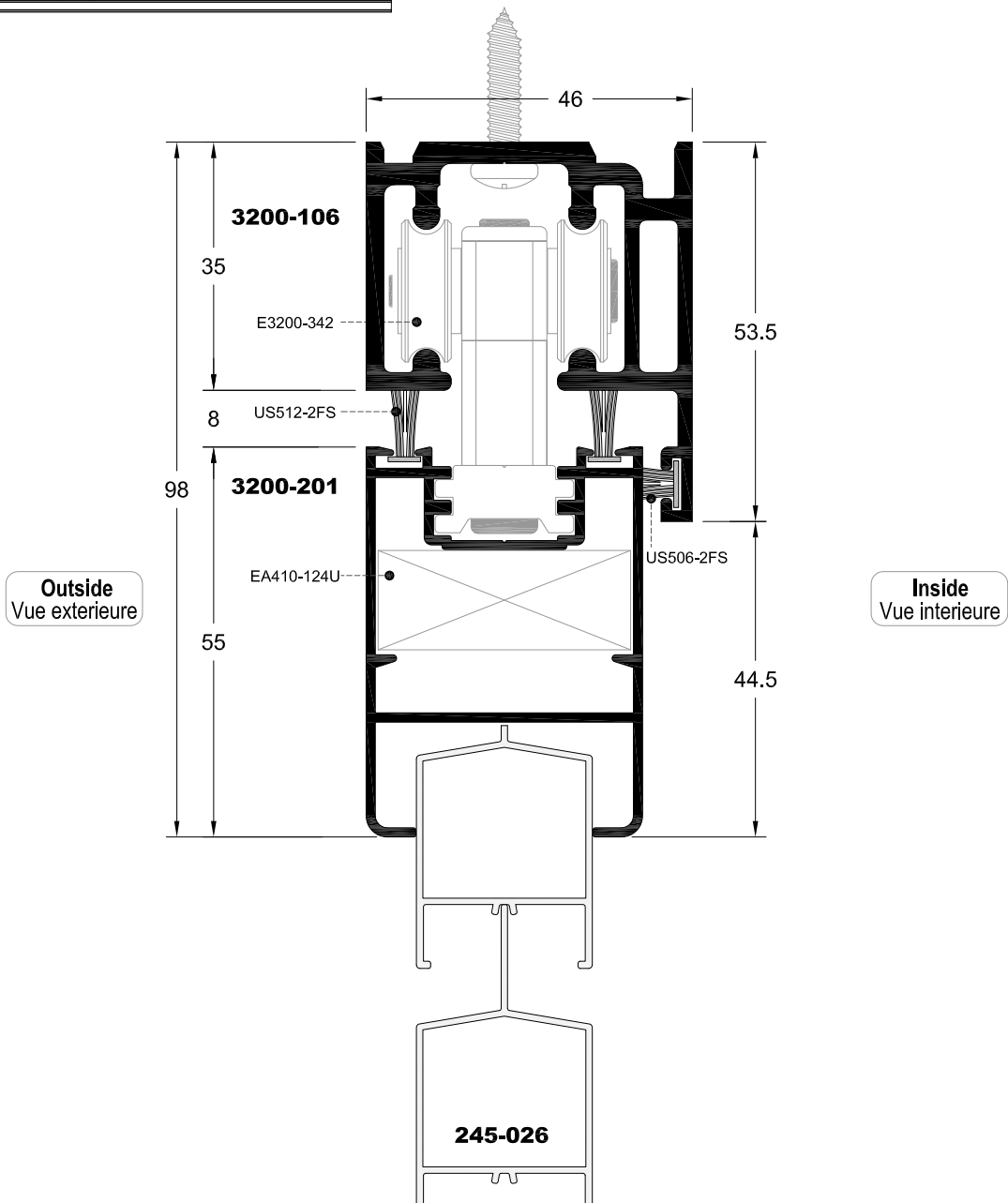

**SECTION OF TRIPLE SASH FOLDING SYSTEM**  
**SECTION D' ACCORDÉON A TROIS VANTAIL**

**FRONT VIEW**  
**VUE DE FACE**

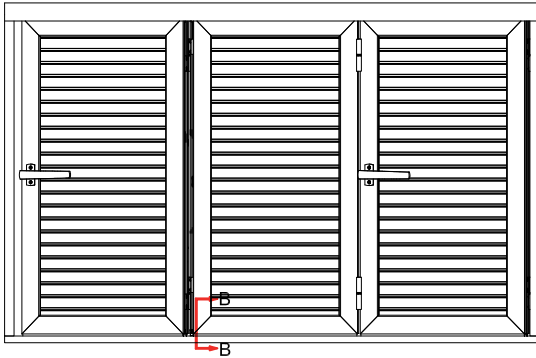

**TOP VIEW**  
**VUE DE DESSUS**

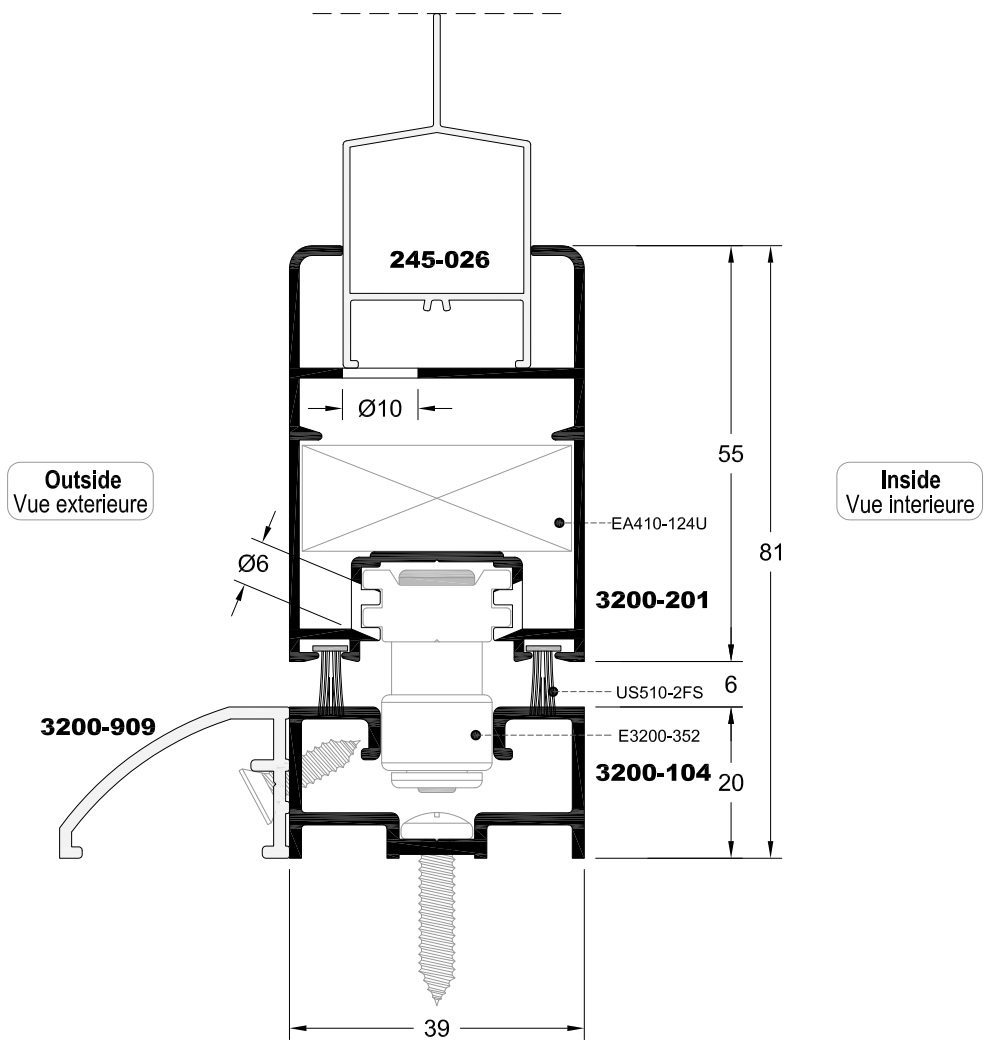

### SECTION OF TRIPLE SASH FOLDING SYSTEM SECTION D' ACCORDÉON A TROIS VANTAIL

**FRONT VIEW**  
VUE DE FACE

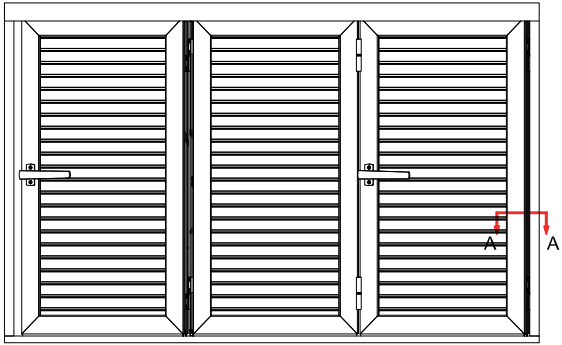

**TOP VIEW**  
VUE DE DESSUS



**Outside**  
Vue extérieure

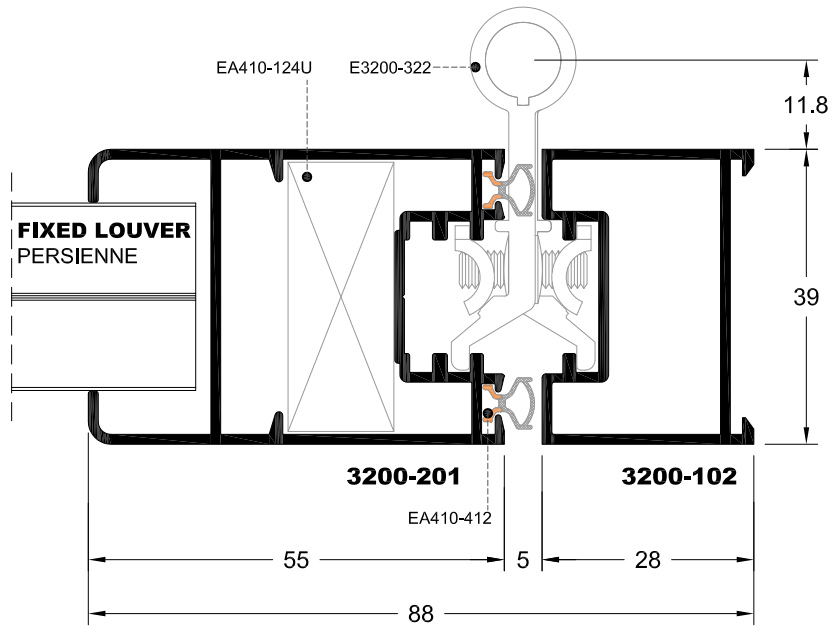

**Inside**  
Vue intérieure

**SECTION OF TRIPLE SASH FOLDING SYSTEM**  
**SECTION D' ACCORDÉON A TROIS VANTAIL**

**FRONT VIEW**  
**VUE DE FACE**

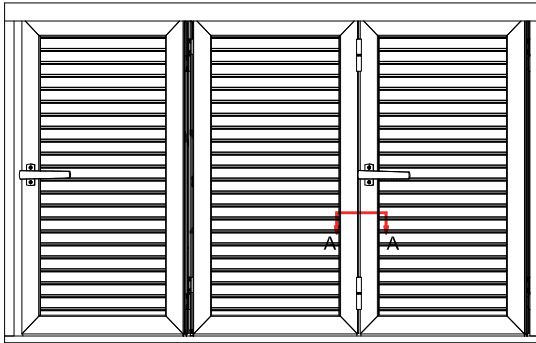

**TOP VIEW**  
**VUE DE DESSUS**



**Outside**  
 Vue extérieure

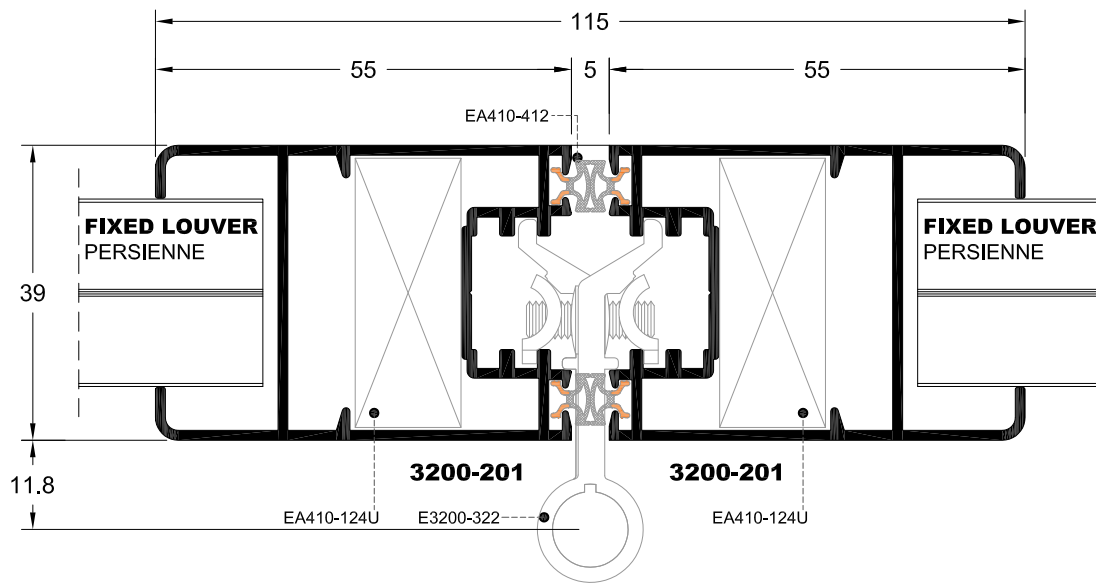

**Inside**  
 Vue intérieure

**SECTION OF TRIPLE SASH FOLDING SYSTEM**  
**SECTION D' ACCORDÉON A TROIS VANTAIL**

**FRONT VIEW**  
**VUE DE FACE**

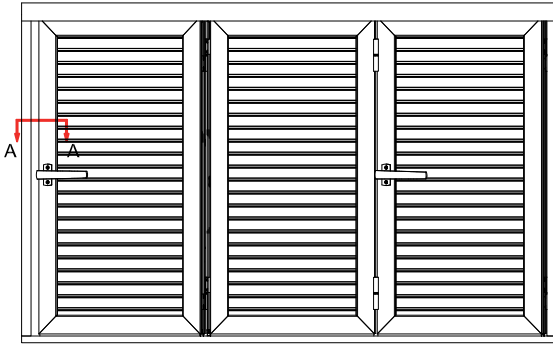

**TOP VIEW**  
**VUE DE DESSUS**

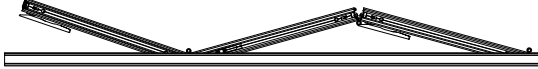

**Outside**  
 Vue extérieure

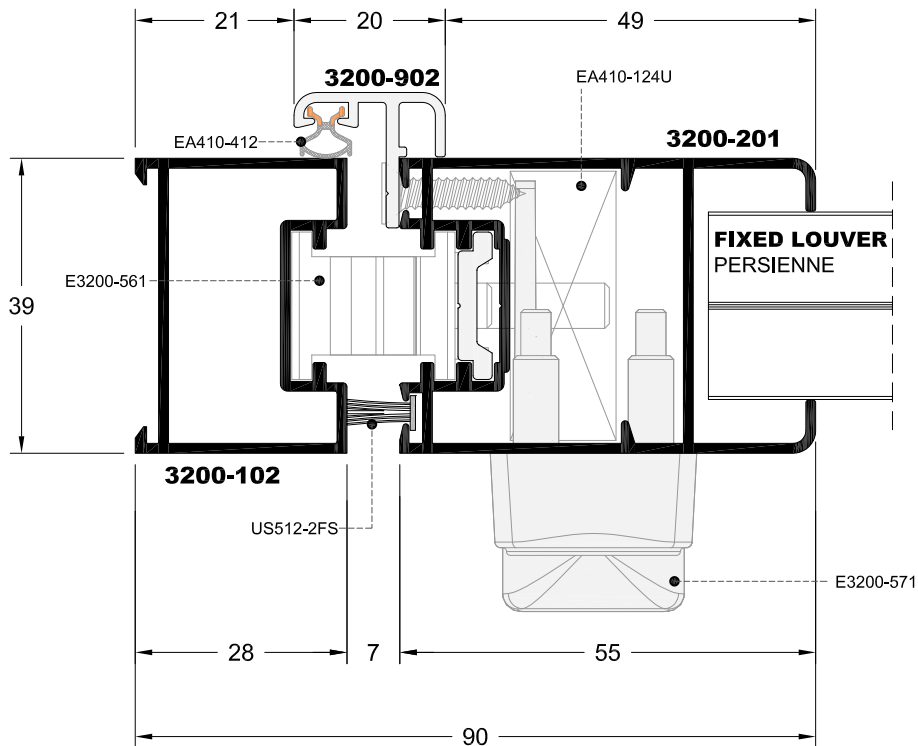

**Inside**  
 Vue intérieure

**SECTION OF TRIPLE SASH FOLDING SYSTEM**  
**SECTION D' ACCORDÉON A TROIS VANTAIL**

**FRONT VIEW**  
**VUE DE FACE**

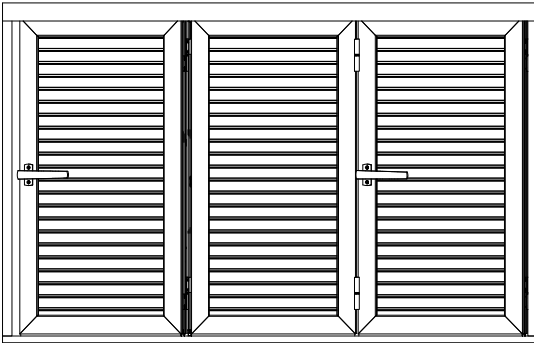

**TOP VIEW**  
**VUE DE DESSUS**

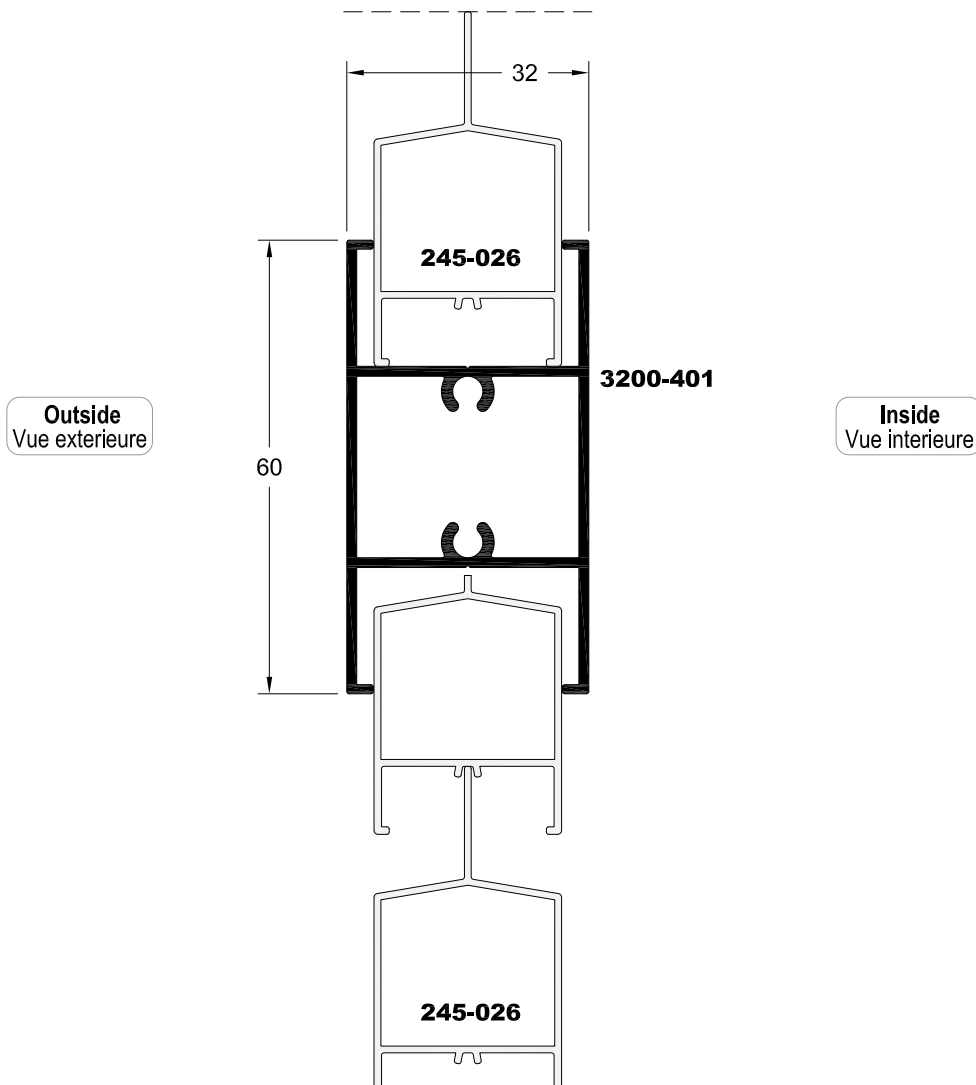

**FRAME ASSEMBLY FOR FOLDING SYSTEM**  
**FABRICATION DU CHÂSSIS POUR SYSTÈME ACCORDÉON**

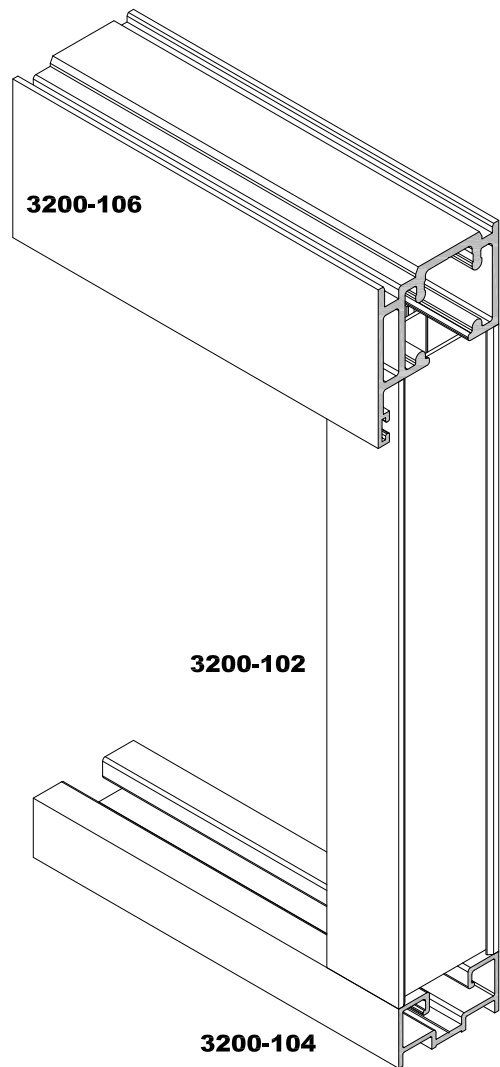
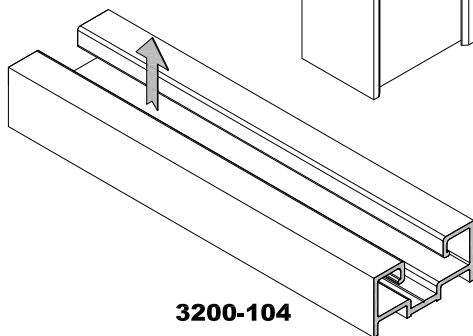
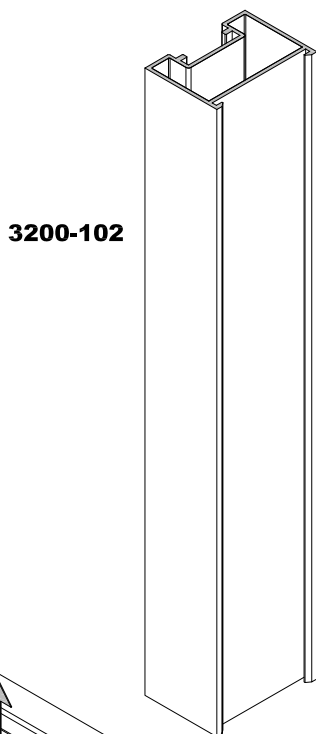
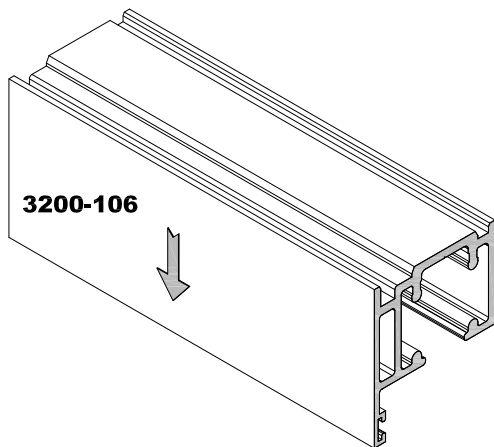



**UPPER ROLLER ASSEMBLY FOR FOLDING SYSTEM**  
**INSTALLATION DE ROULEAU SUPERIEURE DANS SYSTEME ACCORDÉON**

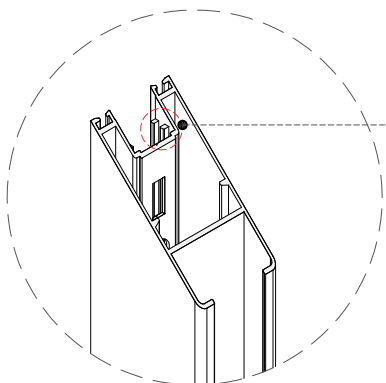
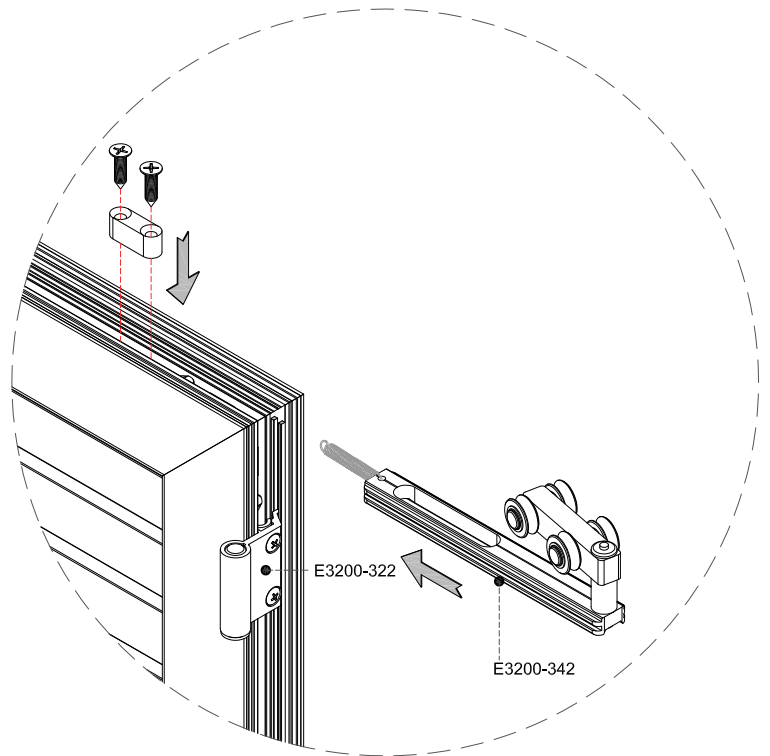
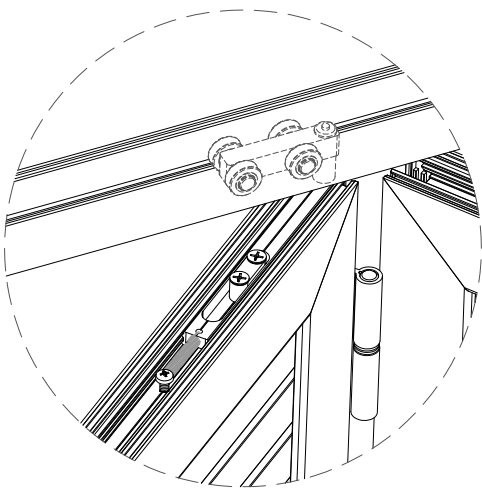
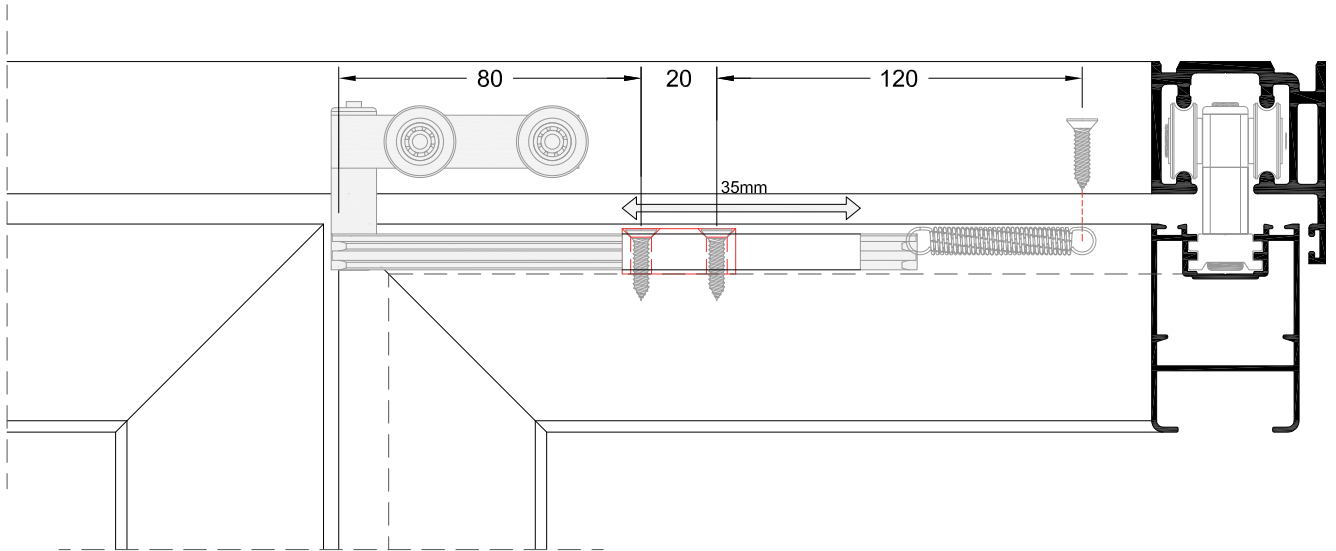

**Milling**  
Traitement

## **BOTTOM ROLLER ASSEMBLY FOR FOLDING SYSTEM** **INSTALLATION DE ROULEAU INFÉRIEUR DANS SYSTÈME ACCORDÉON**

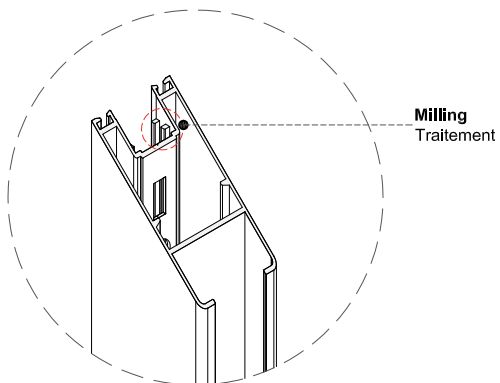
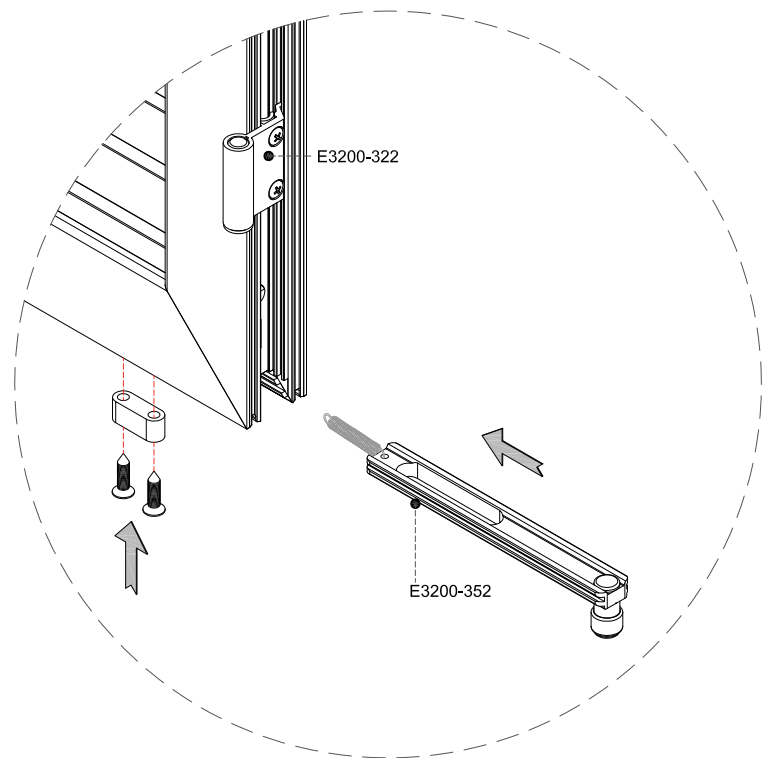
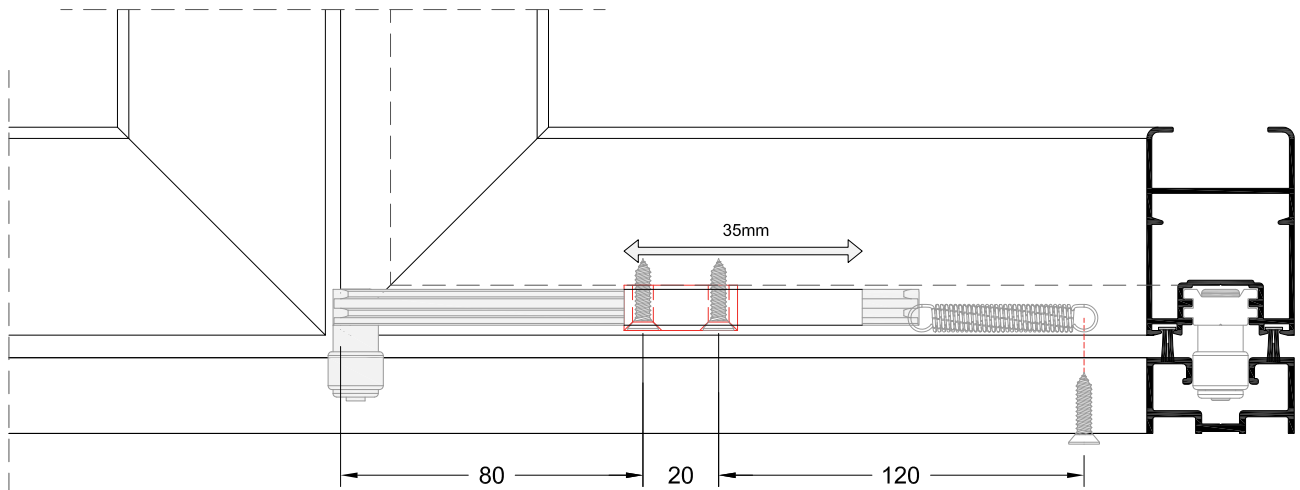

**ASSEMBLY OF PIN ON THE ROD**  
**INSTALLATION D'AXE**

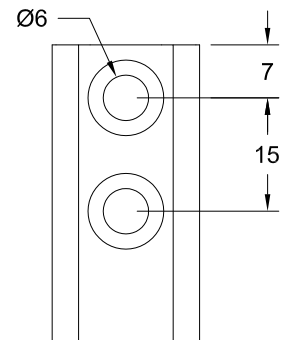
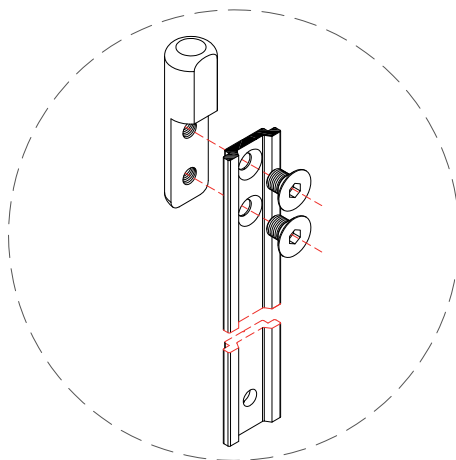
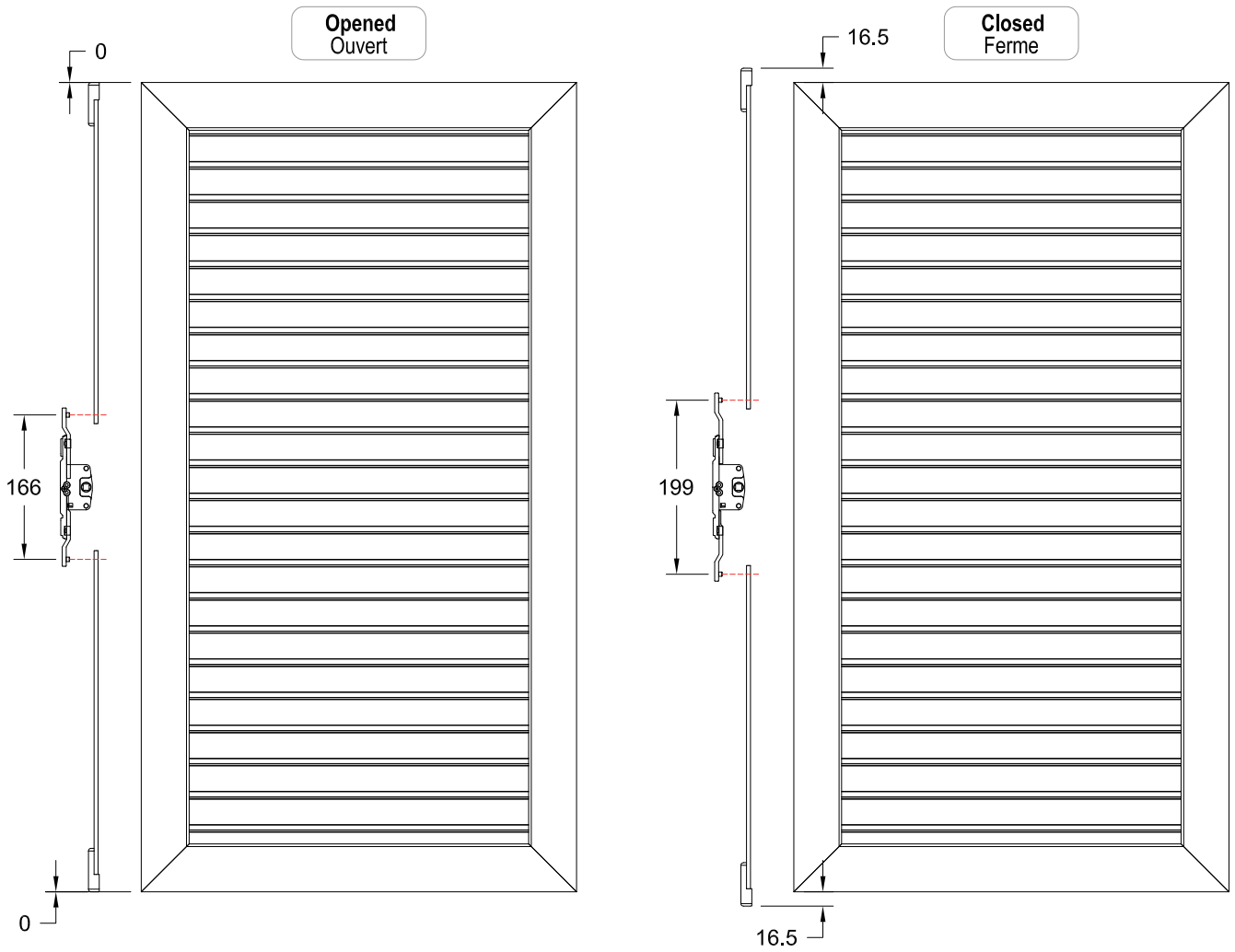

**INSTRUCTIONS OF FOLDING CONSTRUCTION**  
**INSTRUCTIONS DE FABRICATION**

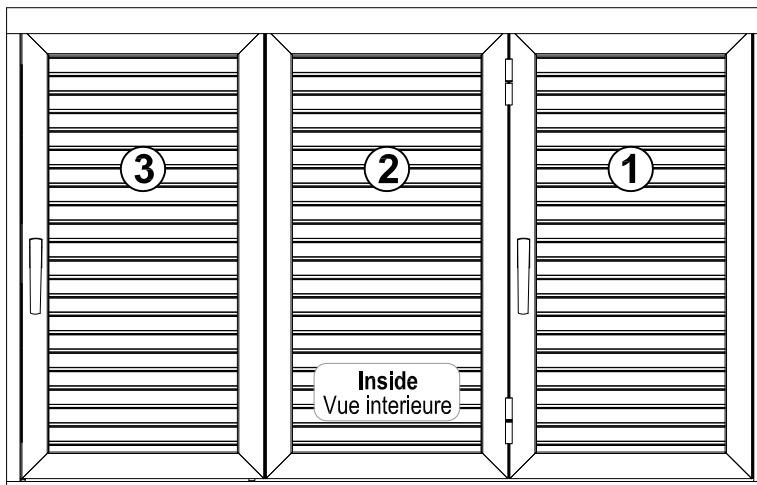

- **Cut and assembling the sashes according the cutting dimensions**
- **Install upper and bottom guide. Continue with side guides**
- **Hung the sash 1 in already mounted hinges on the frame**
- **Continue with the sash 2 (attention: we have already taken care to make the necessary treatments to upper guide for the insertion of the roller)**
- **Continue with the sash 3 and so on**
  
- Couper et assembler le vantail en vertu de mesures de decoupage
- Placement du rail superieure et enferieure sur le mur
- Suspendre le vantail sur les charnières
- Continuer avec le deuxieme vantail (attention: il faut installer le rabatteur)
- Continuer avec le troisieme vantail etc

**UPPER GUIDE'S MILLING FOR INSTALLATION OF ROLLER**  
**MOULURE DE RAIL SUPERIEURE POUR L'INSERTION DU RABATTEUR**

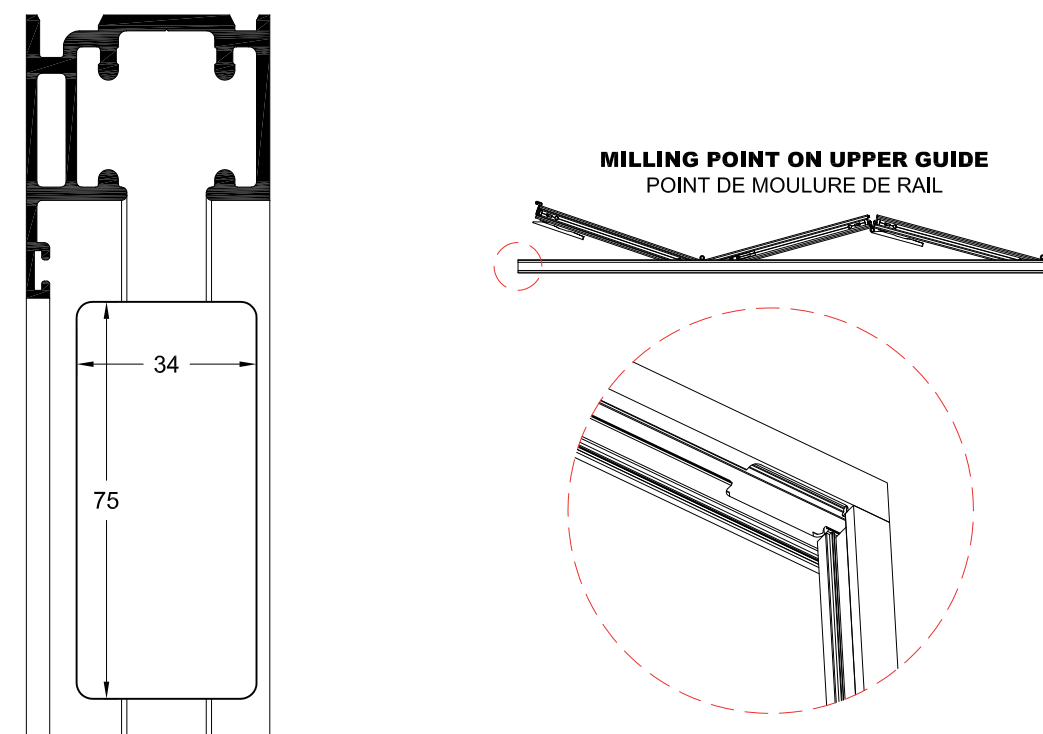

**CUTTING CALCULATIONS FOR FOLDING SYSTEM**  
**MESURES DE DECOUPAGE POUR ACCORDÉON**

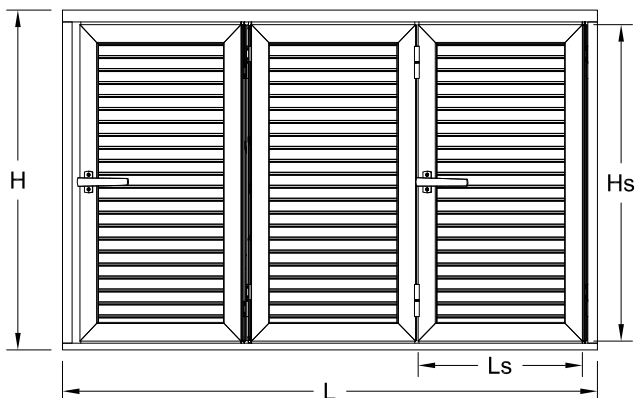

- H = **Frame height**  
Hauteur du fabrication
- L = **Frame width**  
Largeur du fabrication
- Hs = **Sash height**  
Hauteur du vantail
- Ls = **Sash width**  
Largeur du vantail

**Triple folding**  
 Accordéon a trois vantaux



$Hs = H - 69mm$

$Ls = L - 78/3mm$

**Quad folding**  
 Accordéon a quatre vantaux



$Hs = H - 69mm$

$Ls = L - 83/4mm$

**Five sashes folding**  
 Accordéon a cinq vantaux



$Hs = H - 69mm$

$Ls = L - 88/5mm$

**Six sashes folding**  
 Accordéon a six vantaux

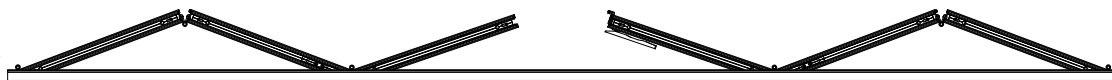

$Hs = H - 69mm$

$Ls = L - 93/6mm$



**SH 3200**  
ALUMINIUM SYSTEMS

Sliding  
Coulissant



### SECTION OF DOUBLE SLIDING SASH SECTION DE COULISSANT A DEUX VANTAUX

**FRONT VIEW**  
VUE DE FACE

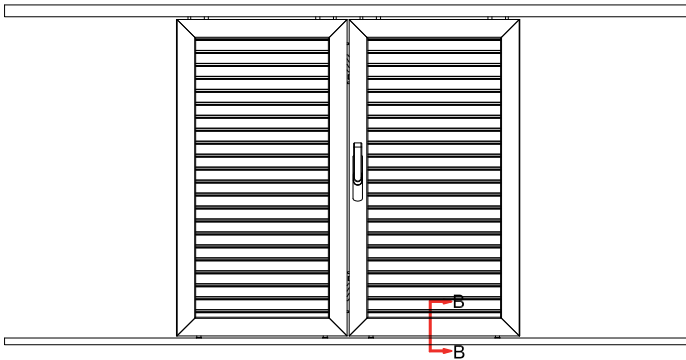

**TOP VIEW**  
VUE DE DESSUS

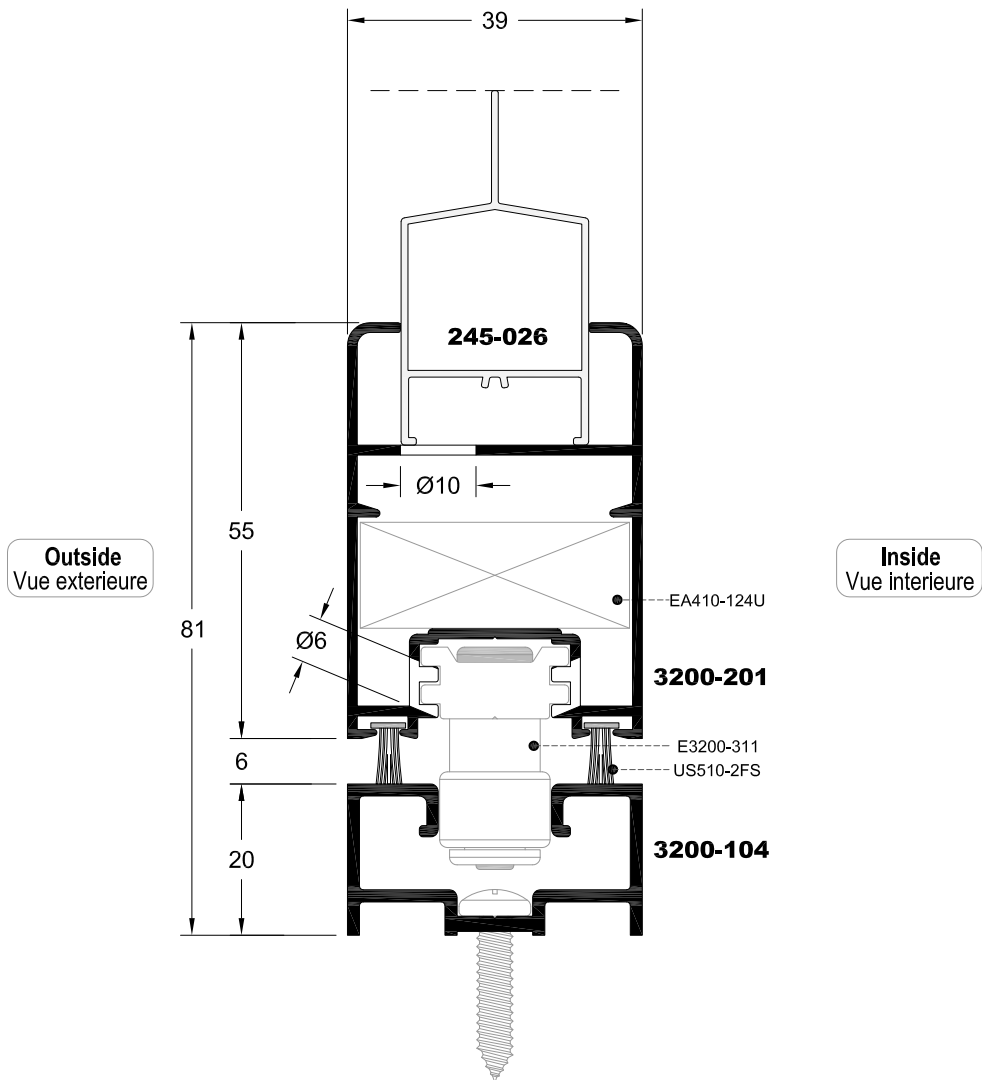



**SECTION OF DOUBLE SLIDING SASH**  
**SECTION DE COULISSANT A DEUX VANTAUX**

**FRONT VIEW**  
**VUE DE FACE**

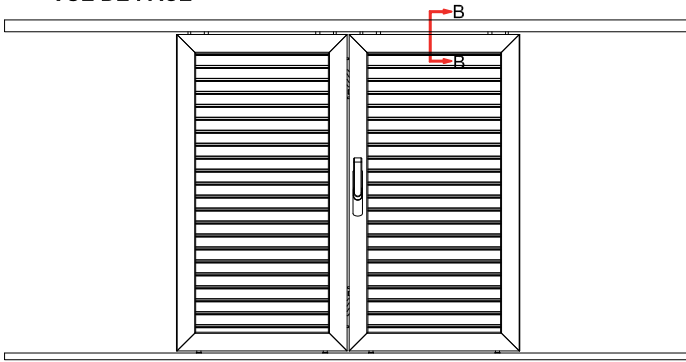

**TOP VIEW**  
**VUE DE DESSUS**

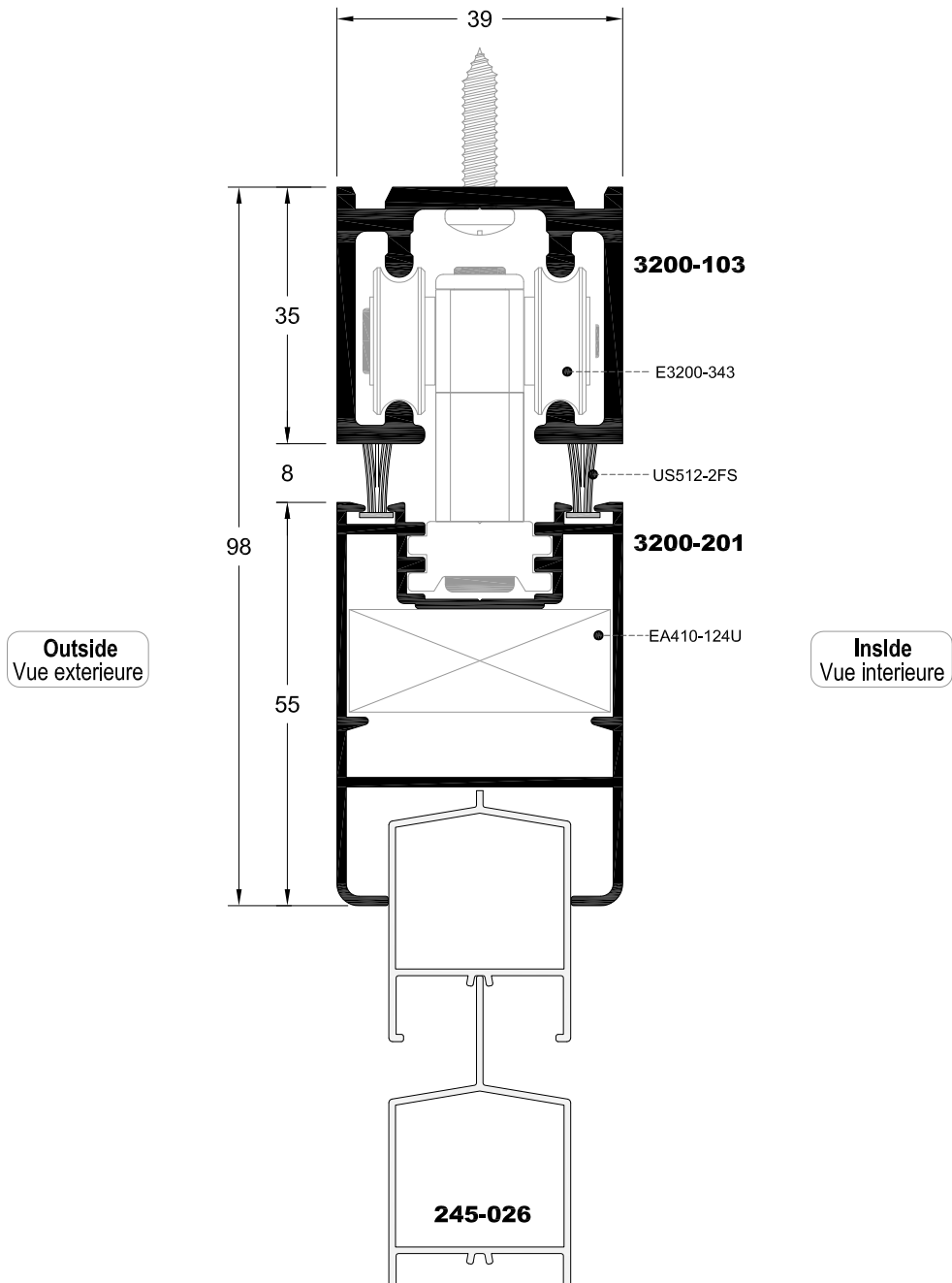

**SECTION OF DOUBLE SLIDING SASH**  
**SECTION DE COULISSANT A DEUX VANTAUX**

**FRONT VIEW**  
**VUE DE FACE**

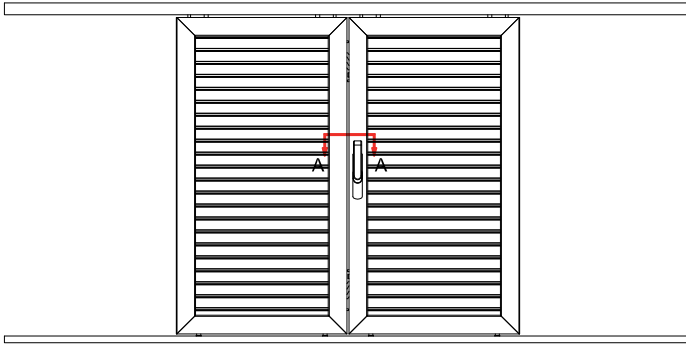

**TOP VIEW**  
**VUE DE DESSUS**

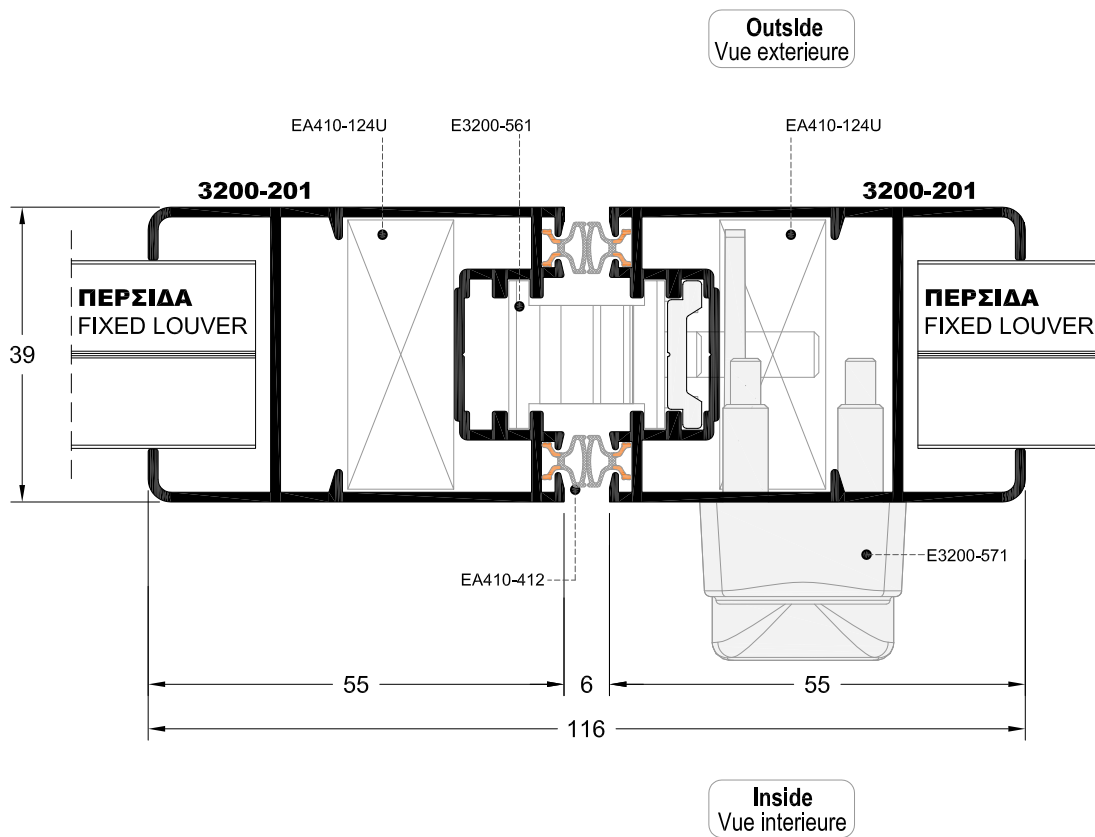

**SECTION OF SINGLE SLIDING SASH**  
**SECTION DE COULISSANT A UNE VANTAIL**

**FRONT VIEW**  
**VUE DE FACE**

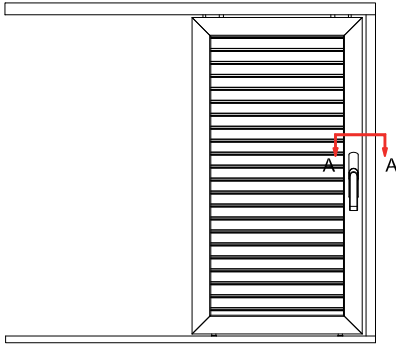

**TOP VIEW**  
**VUE DE DESSUS**

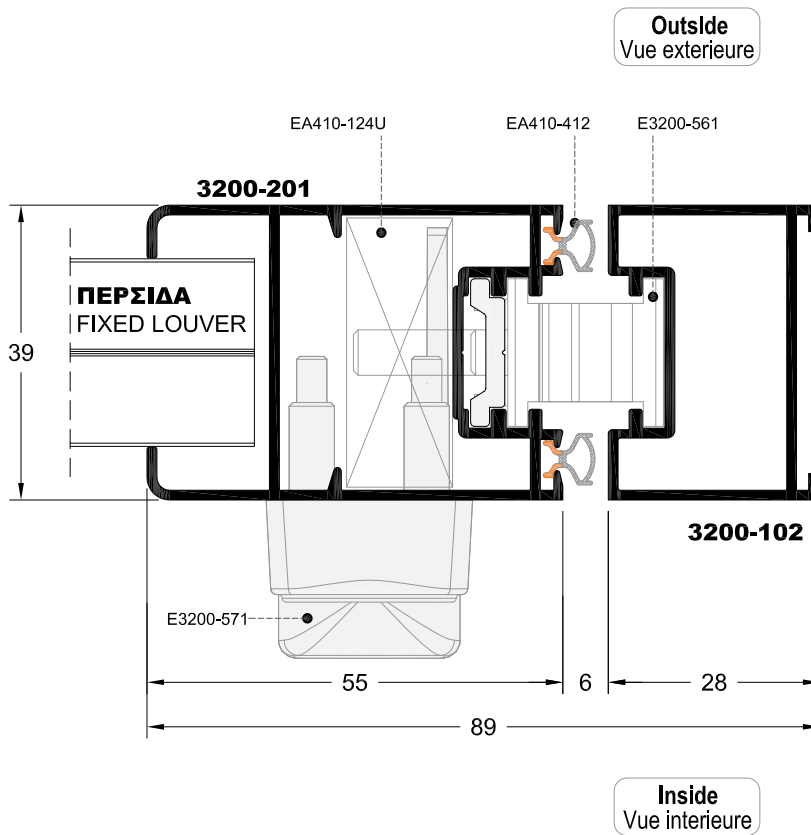
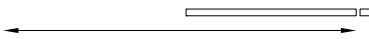

**UPPER AND BOTTOM ROLLER ASSEMBLY FOR SLIDING SYSTEM**  
**INSTALLATION DU RABATTEUR SUPÉRIEURE ET INFÉRIEURE SUR SYSTÈME COULISSANT**

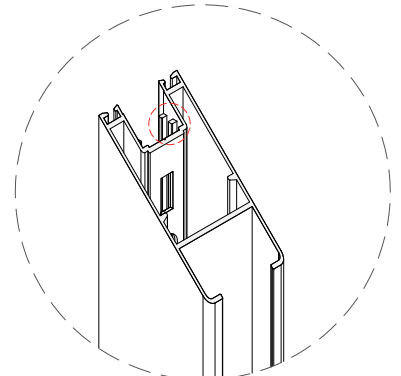
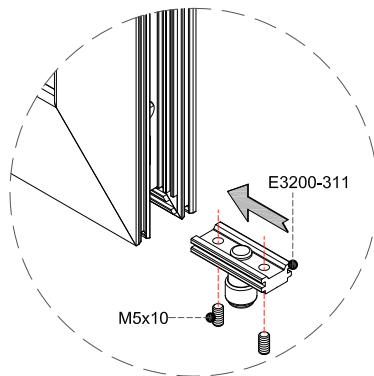
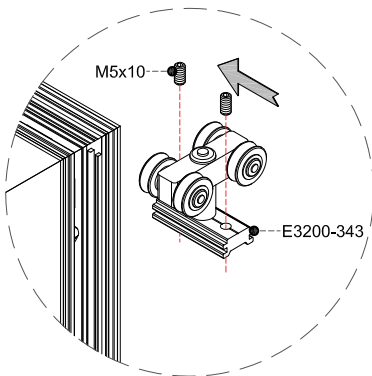
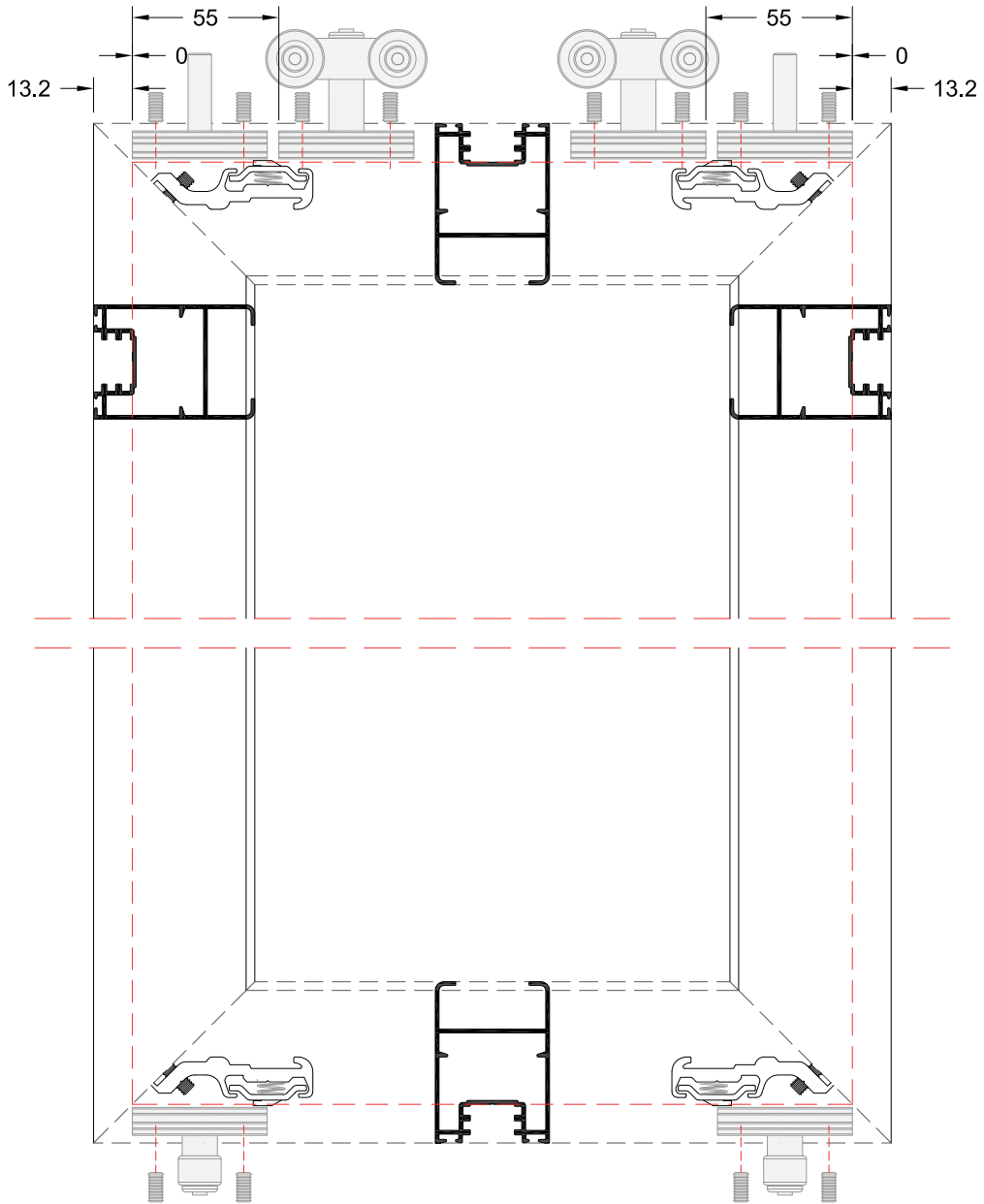

**STOPPER INSTALLATION**  
**INSTALLATION DU ARRÊT DU COULISSANT**

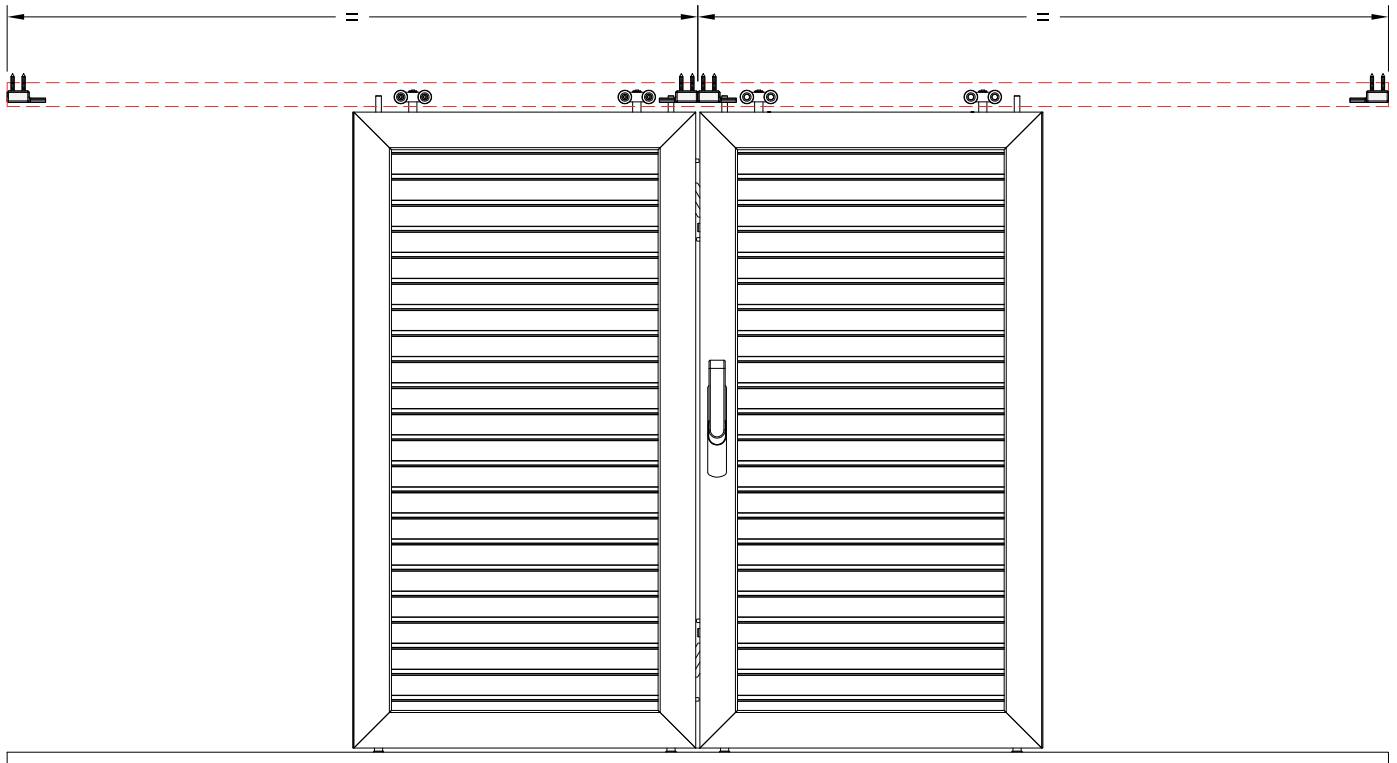

**\*In case we don't want mount stops on the driver, alternatively we can use setscrew M6**

**\*Dans le cas ou ne nous voulons pas le fixation du stopper en perçant un trou sur le conducteur, alternativement on peut utiliser tige filetée M6**

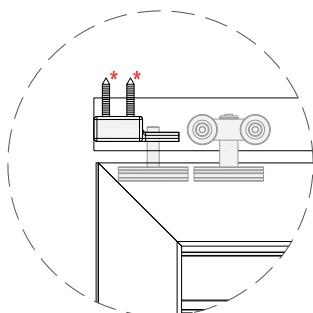
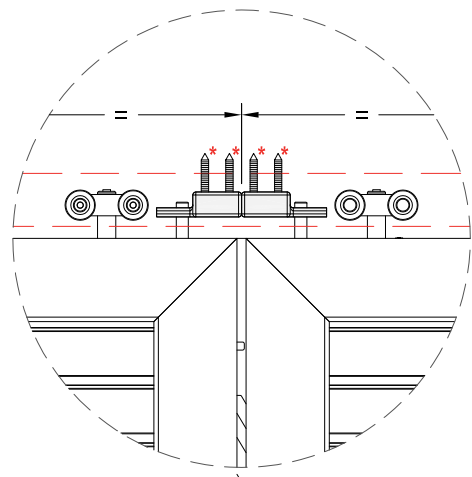

**CUTTING CALCULATIONS FOR SLIDING SYSTEM**  
**MESURES DE DECOUPAGE**

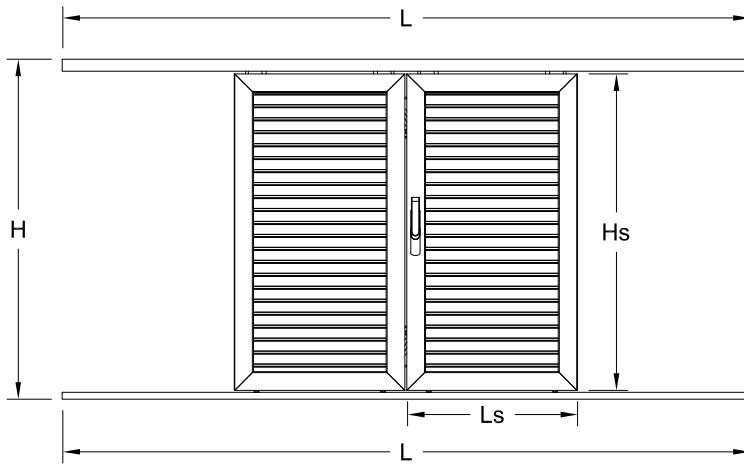

- H = **Frame height**  
Hauteur du fabrication
- L = **Frame width**  
Largeur du fabrication
- Hs = **Sash height**  
Hauteur du vantail
- Ls = **Sash width**  
Largeur du vantail

**Single**

Avec une vantail

$$Hs = H - 69\text{mm}$$

$$\text{min } L = (Ls \times 2) + 40$$

**Double**

Avec deux vantaux

$$Hs = H - 69\text{mm}$$

$$\text{min } L = (Ls \times 4) + 15$$

**SH 3200**  
ALUMINIUM SYSTEMS

Movable louver  
Persienne mobile



## CONSTRUCTION STEPS FOR MOVABLE LOUVER WITH ROTARY HANDLE ÉTAPES DE CONSTRUCTION POUR LES PERSIENNES MOBILE AVEC POIGNÉE ROTATIVE

### Construction steps - Etapes de construction

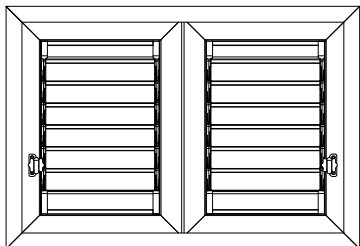

Install the mechanism (3) to the rear of bar system (1) and mark the drive shaft (Figure 1 a). Fit the clip profile in sash and roll out the holes for the rotor (Figure 1 b). Place the upper and lower plastic trim (4, 5), the profile 540-901 and 540-902 and close the sash with corner joints. Then slide blinds having the clip profile in the open position.

Place the lever motion (3) à l'arrière du système de barre (1) marque de l'arbre d'entraînement (forme 1a). Adapter le fit profil au volet et place les finition en plastic (4,5) le profil 540-901 et 540-902 et fermer le vantail avec les angles de connexion ensuite glisse les volets ayant les échelles en position ouverte.

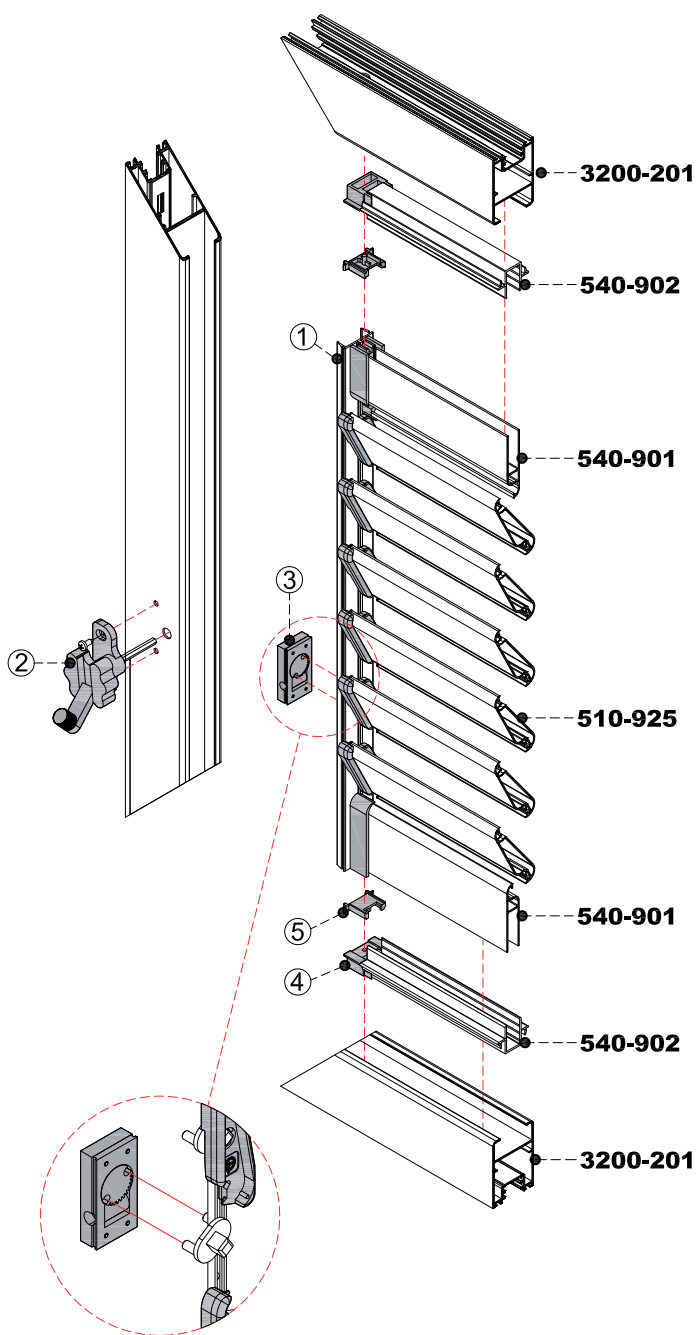

### Fitting rotor to sash Rotor apte à chassis

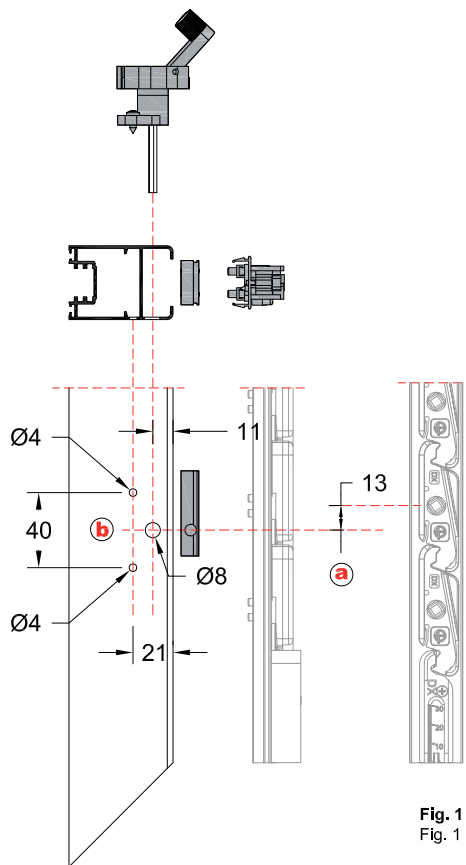

Fig. 1  
Fig. 1



**MOVABLE LOUVER WITH LEVER**

\*\*\*\*\*

**Constructions steps - Etapes de construction**

Arrange the lever movement (d) removing from the bar system (1) the plastic cap (c) (Fig. 2). Fit the clip profile in sash and placed on the lower plastic trim (4, 5), the profiles 540-901 and 540-902. Finally we close the sash with corner joists and slides blinds having the clip profile in the open position.

Pace the lever motion (d) soustrayant le système de barre (1) capuchon en plastique (c) (forme2). Adapter le fit profil au volet et place les finition en plastic (4,5) le profil 540-901 et 540-902. Enfin fermer le vantail avec les angles de connexion et glisse les volets ayant les échelles en position ouverte.

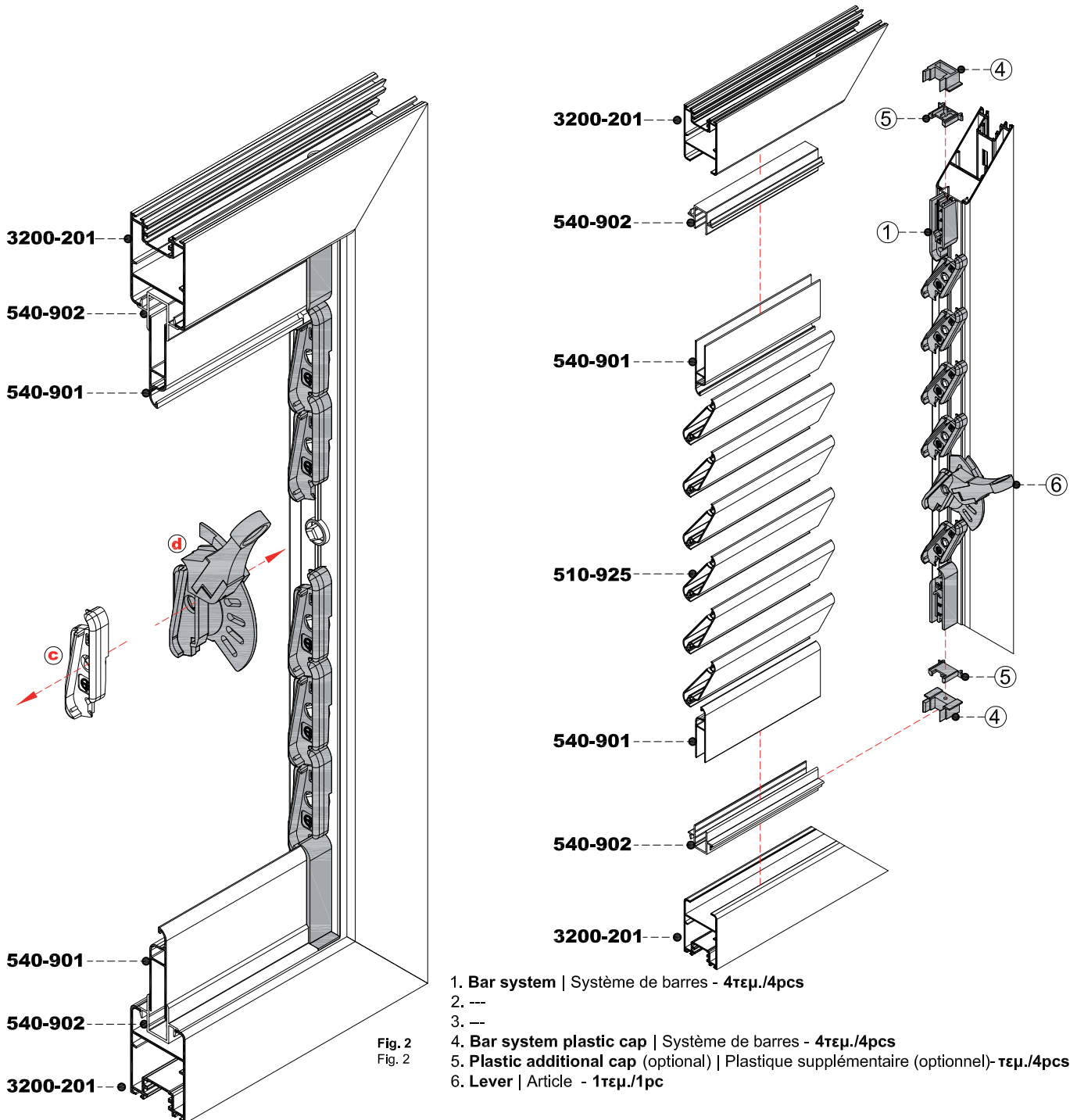
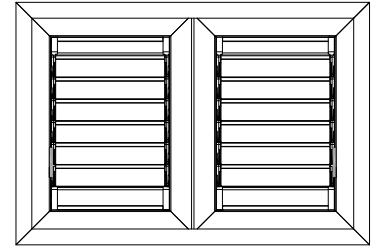

- 1. Bar system | Système de barres - 4τμ./4pcs
- 2. ---
- 3. ---
- 4. Bar system plastic cap | Système de barres - 4τμ./4pcs
- 5. Plastic additional cap (optional) | Plastique supplémentaire (optionnel)- τμ./4pcs
- 6. Lever | Article - 1τμ./1pc

## MECHANISM CHOICE CHOIX MECHANISM VOLET MOBILE

<b>Movable louver mechanism</b> Mechanism volet mobile		
<b>L</b> Number of louvers Numero des lames	<b>H mm</b> Bar system height Hautere systeme de barre	<b>VL min(mm)*</b>
6	437	382
7	492	437
8	547	492
9	602	547
10	657	602
11	712	657
12	767	712
13	822	767
14	877	822
15	932	877
16	987	932
17	1042	987
18	1097	1042
19	1152	1097
20	1207	1152
21	1262	1207
22	1317	1262
23	1372	1317
24	1427	1372
25	1482	1427
26	1537	1482
27	1592	1537
28	1647	1592
29	1702	1647
30	1757	1702
31	1812	1757
32	1867	1812

Bar system's height may be increased 4,5mm or 9mm by adding plastic cap up-down

Le hauteur de systeme de barre peut etre augmenté 4,5mm ou 9mm en ajoutant plastique supplémentaire au-dessus et en-dessous

**Fitting louver**  
Installation persienne

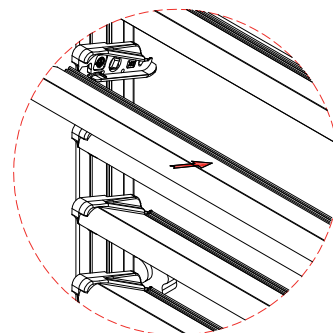

**Plastic cap**  
Plastique supplémentaire

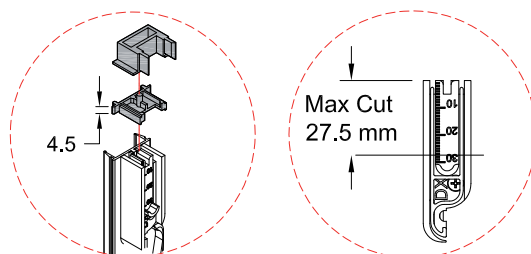

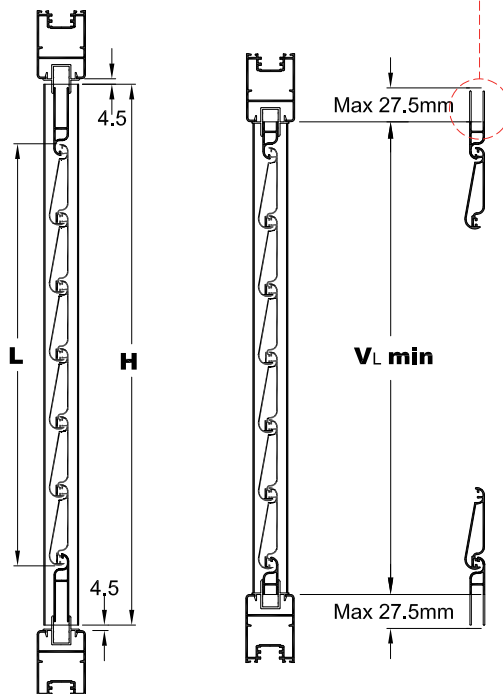
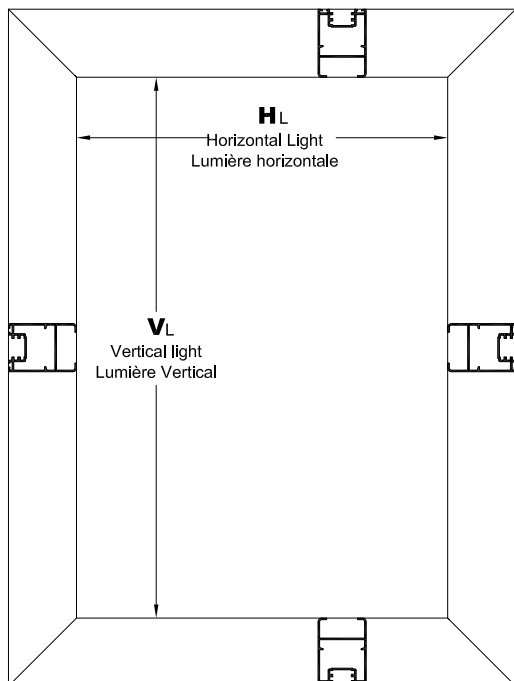

\*VL min = Bar system height minus 55mm (cutting 27.5 mm from each side)

\*Le VL min se référer à l'hauteur du systeme de barre moins 55mm qui se trouve par le coupe de 27,5mm de chaque côté.

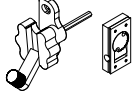

**ΜΕΤΡΑ ΚΟΠΗΣ ΠΕΡΣΙΔΑΣ**  
**CALCULS DE COUPE DE PERSIENNES**

Accessories - Accessoires			
Description	Number of louvers Numero des persiennes	Code	
		25mm	
<b>Bar system (black)</b> Systeme de barre (noir) 	6	EA540-706/01	
	7	EA540-707/01	
	8	EA540-708/01	
	9	EA540-709/01	
	10	EA540-710/01	
	11	EA540-711/01	
	12	EA540-712/01	
	13	EA540-713/01	
	14	EA540-714/01	
	15	EA540-715/01	
	16	EA540-716/01	
	17	EA540-717/01	
	18	EA540-718/01	
	19	EA540-719/01	
	20	EA540-720/01	
	21	EA540-721/01	
	22	EA540-722/01	
	23	EA540-723/01	
	24	EA540-724/01	
	25	EA540-725/01	
	26	EA540-726/01	
	27	EA540-727/01	
	28	EA540-728/01	
	29	EA540-729/01	
	30	EA540-730/01	
	31	EA540-731/01	
	32	EA540-732/01	
	Rotor 		25mm EA540-771/01
	Lever Lever motion 		Right-Droit EA540-772/R Left-Gauche EA540-772/L
	Plastic caps Plastique supplémentaire et finition 	(x4)	25mm EA540-773/01

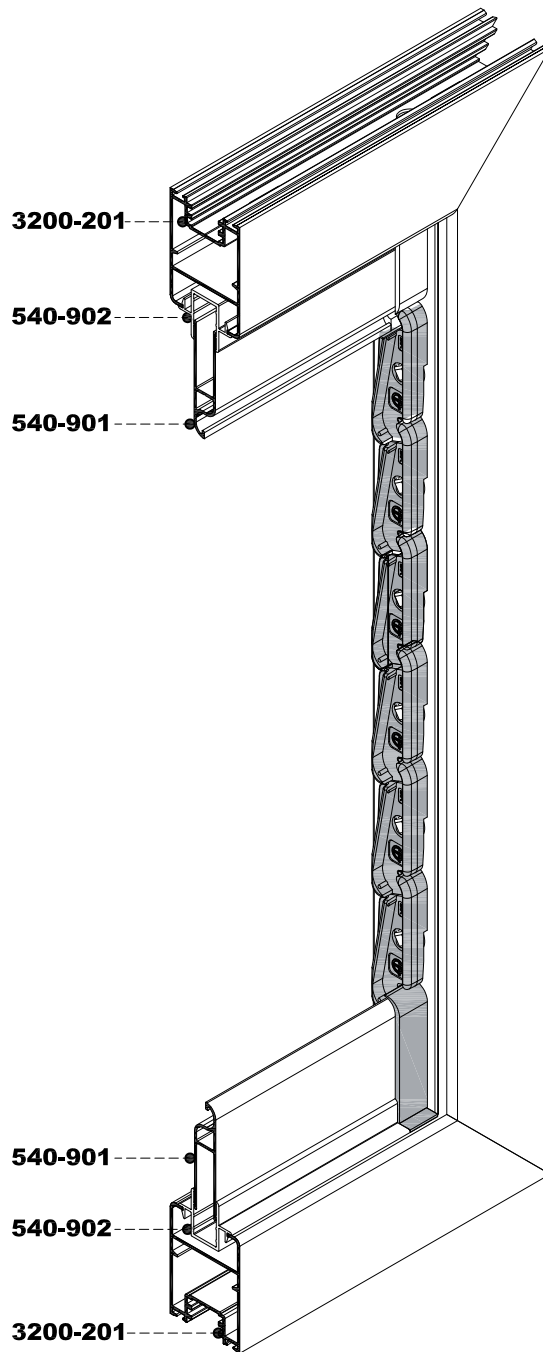
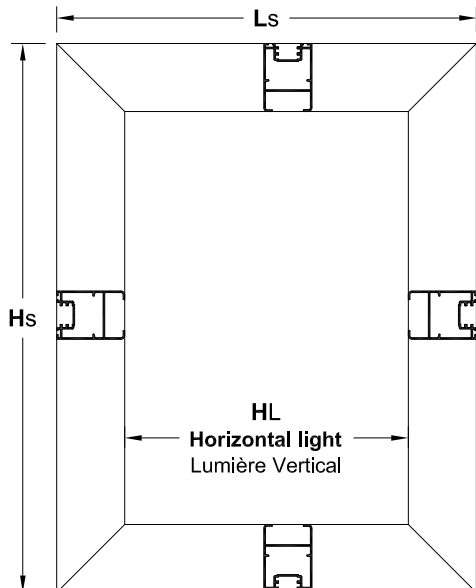

Profile-Profil	Sash-Volet
540-902 (25mm)	HL-34 mm
510-925	HL-14 mm
540-901	HL-26 mm



**SH 3200**  
ALUMINIUM SYSTEMS

Shading  
Système d'ombre



**SECTION OF DOUBLE SLIDING SHADOW SASH**  
**SECTION DE OMBRES COULISSANT A DEUX VANTAUX**

**FRONT VIEW**  
**VUE DE FACE**

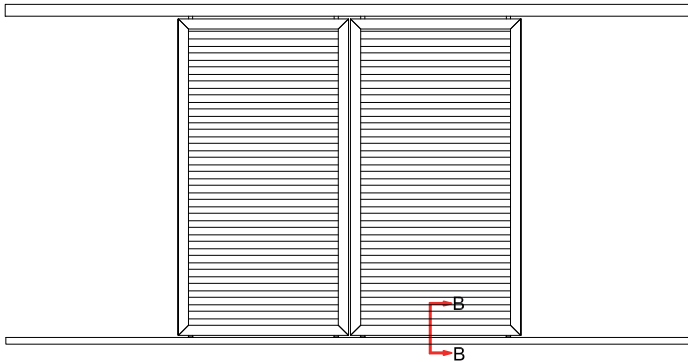

**TOP VIEW**  
**VUE DE DESSUS**

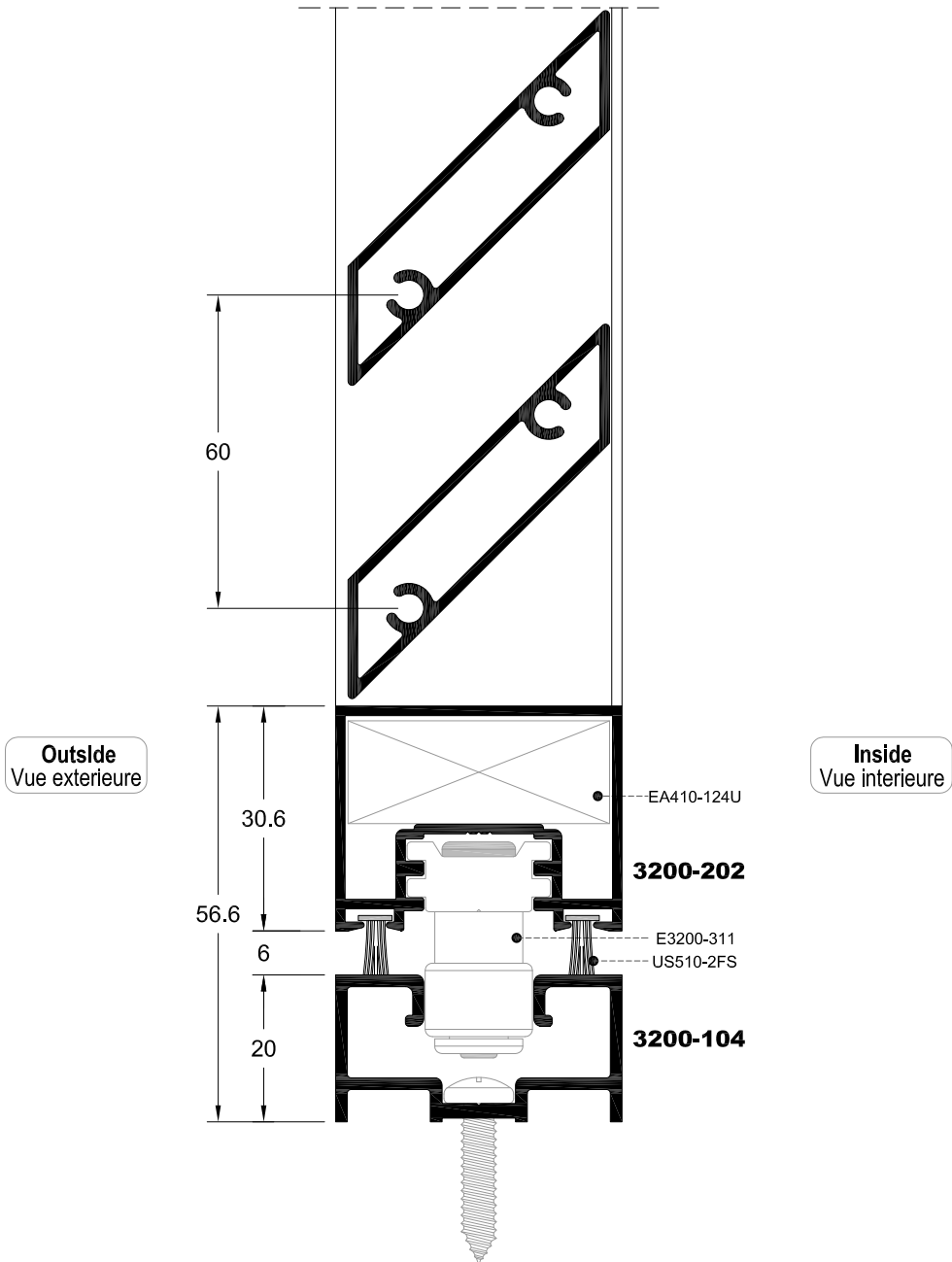
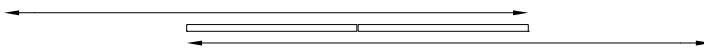

**SECTION OF DOUBLE SLIDING SHADOW SASH**  
**SECTION DE OMBRES COULISSANT A DEUX VANTAUX**

**FRONT VIEW**  
**VUE DE FACE**

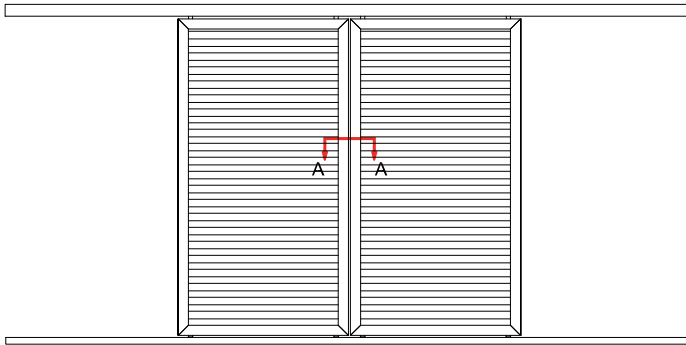

**TOP VIEW**  
**VUE DE DESSUS**

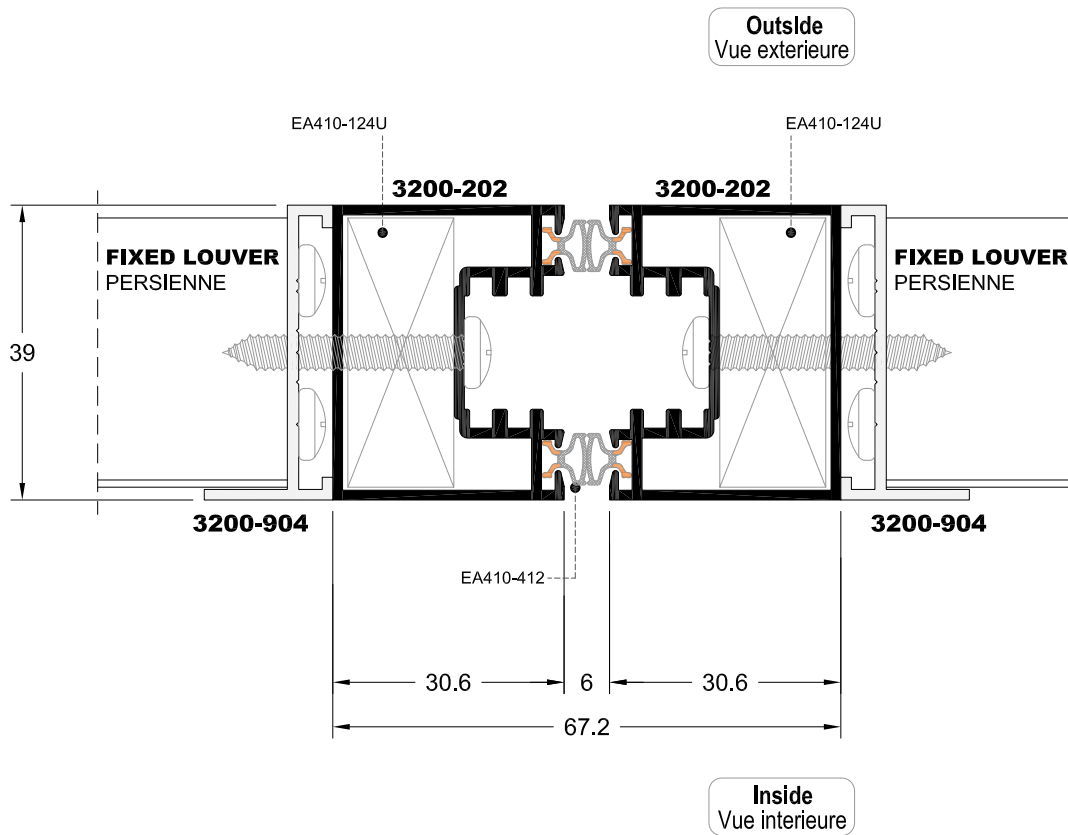
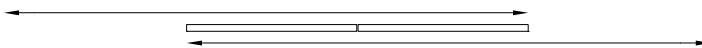

**SECTION OF DOUBLE SLIDING SHADOW SASH**  
**SECTION DE OMBRES COULISSANT A DEUX VANTAUX**

**FRONT VIEW**  
**VUE DE FACE**

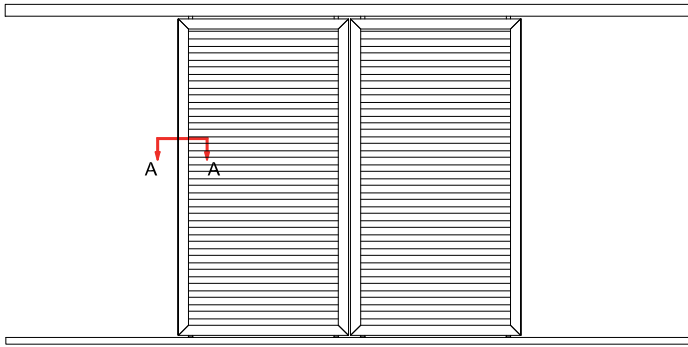

**TOP VIEW**  
**VUE DE DESSUS**

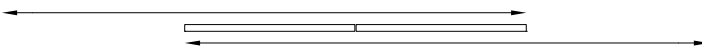

**Outside**  
**Vue extérieure**

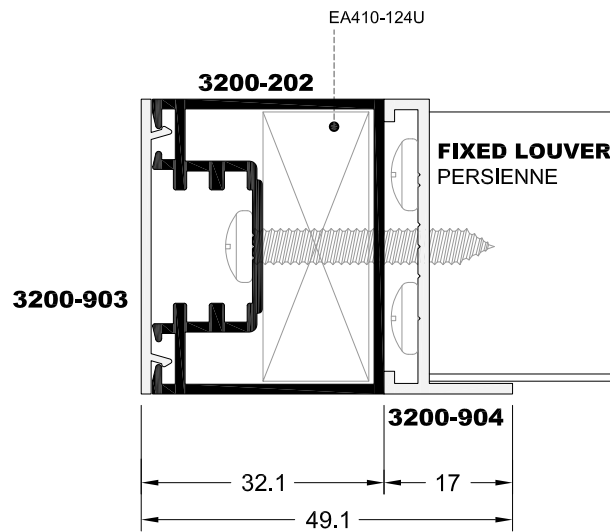

**Inside**  
**Vue intérieure**



**FIXED LOUVER ASSEMBLY**  
**INSTALLATION DE PERSIENNE FIXE**

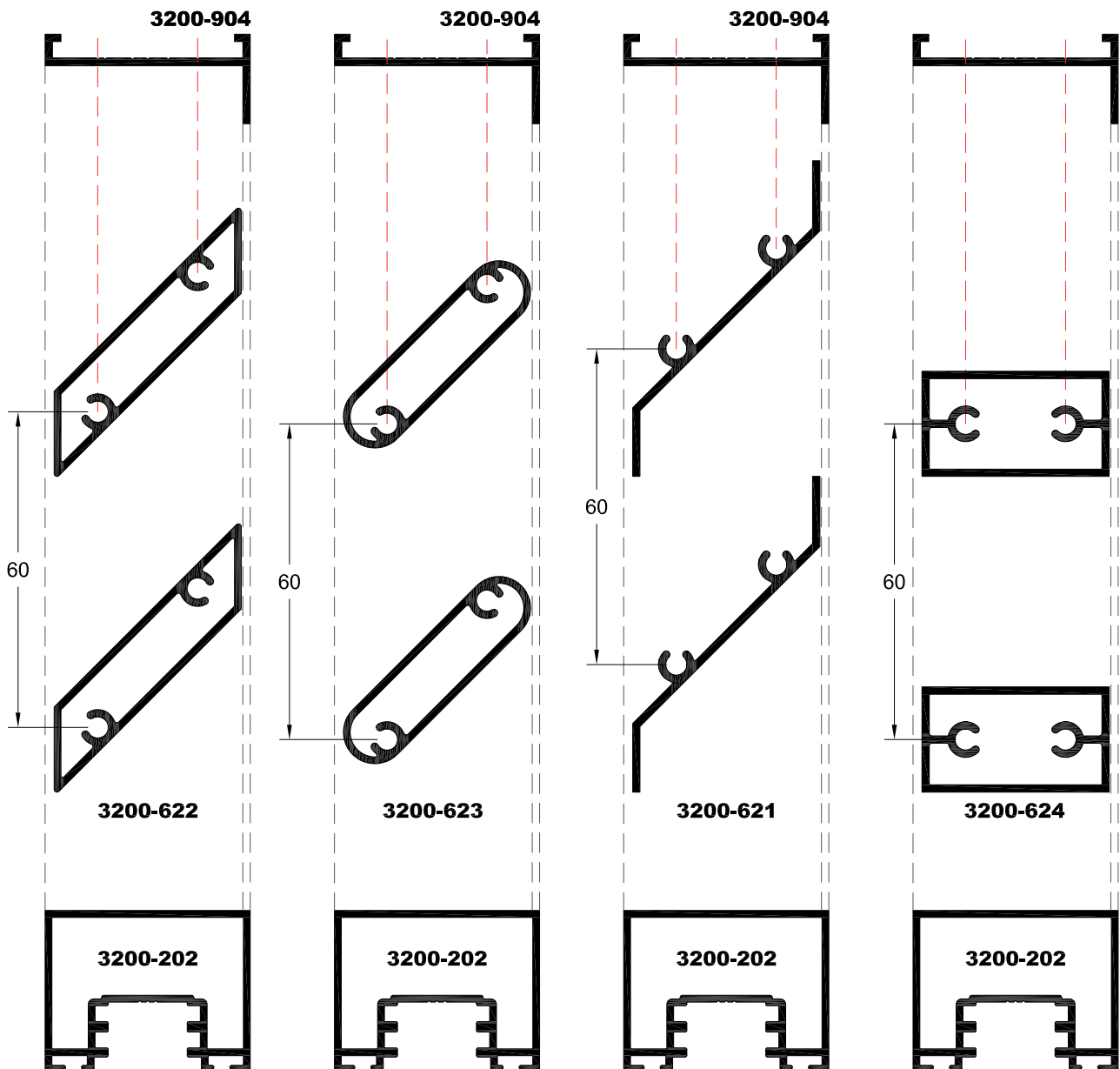
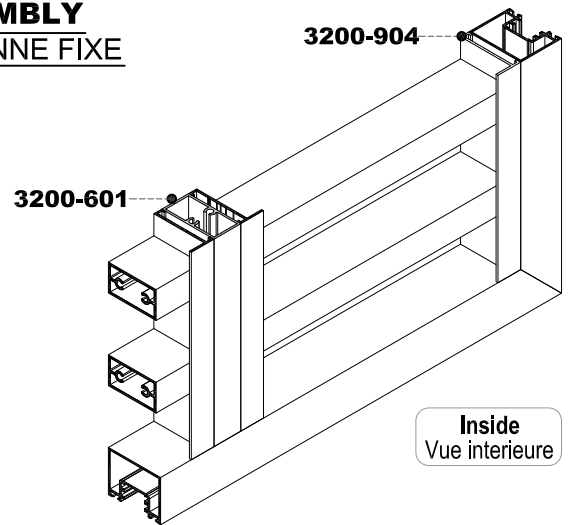

# FIXED LOUVER ASSEMBLY INSTALLATION DE PERSIENNE FIXE

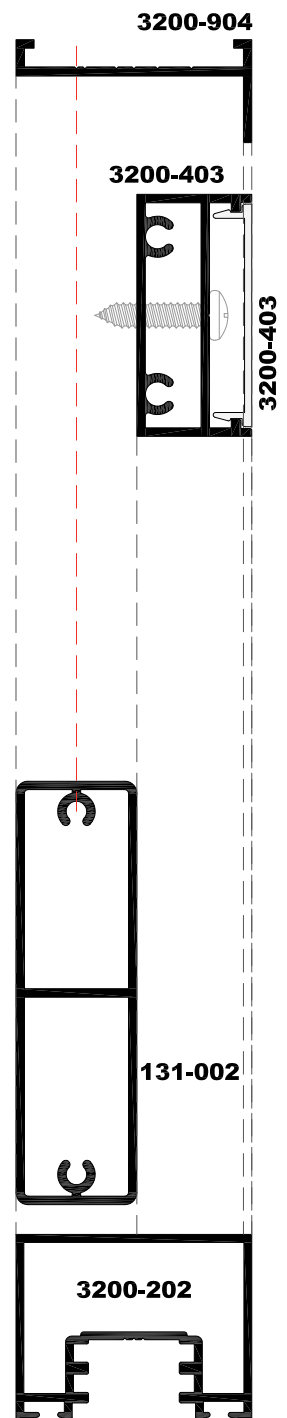
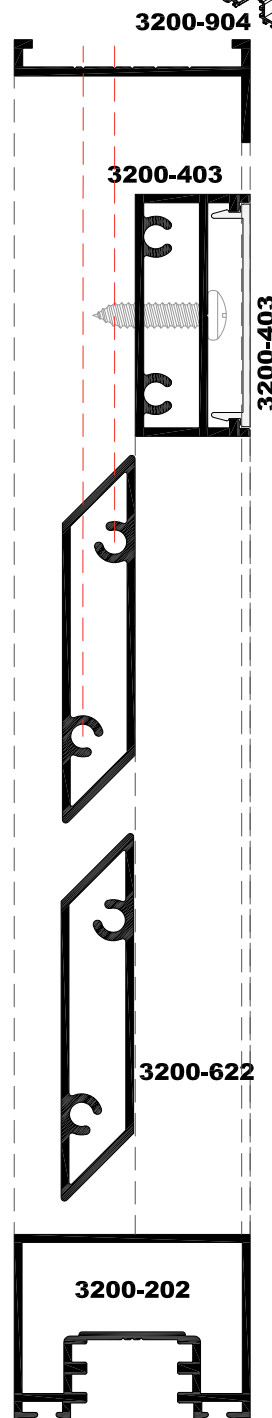
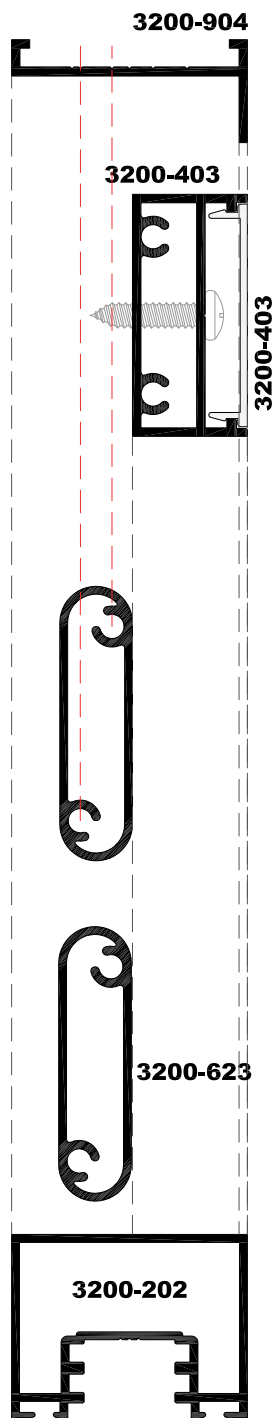
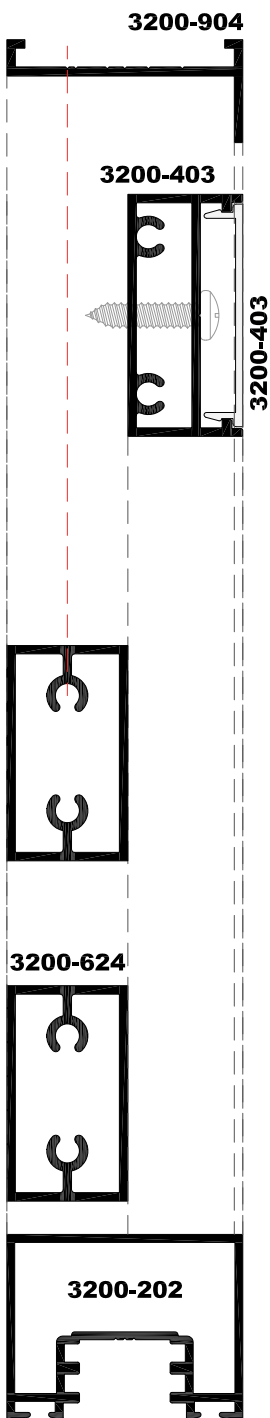
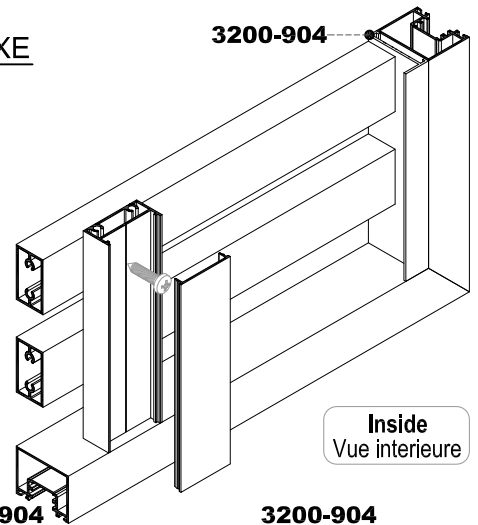

**EXTERNAL 3D VIEW OF FIXED LOUVER**  
**3D IMAGING DE PERSIENNE FIXE**

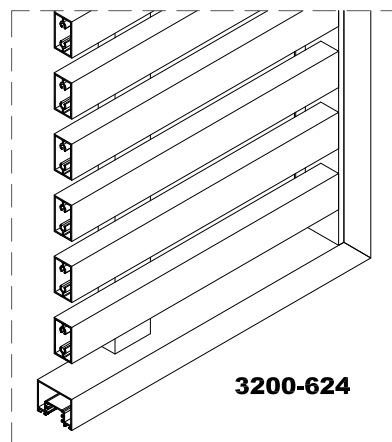
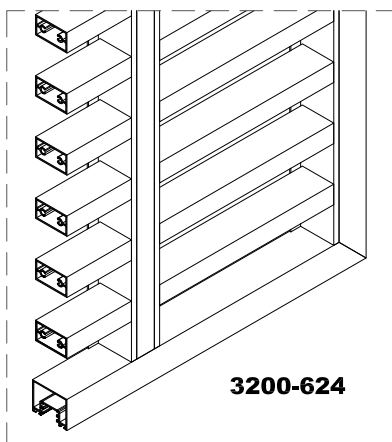
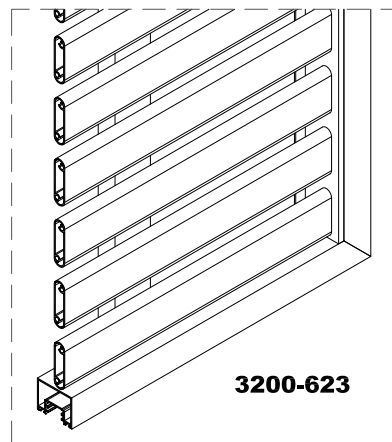
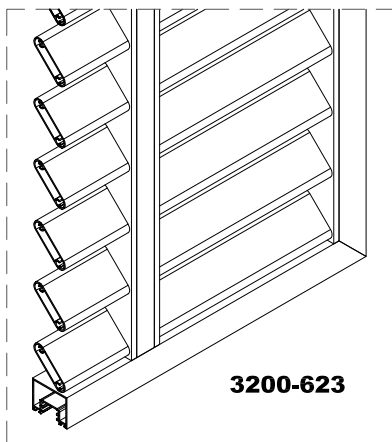
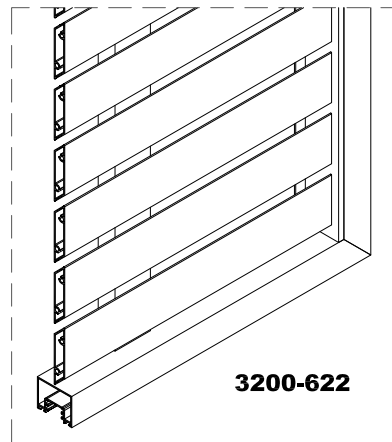
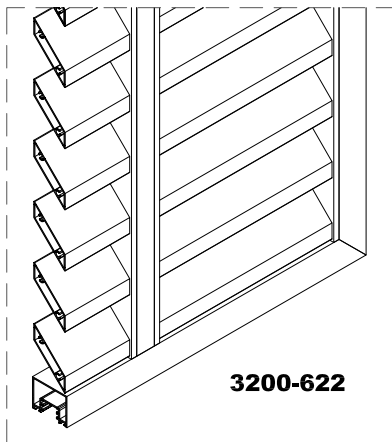
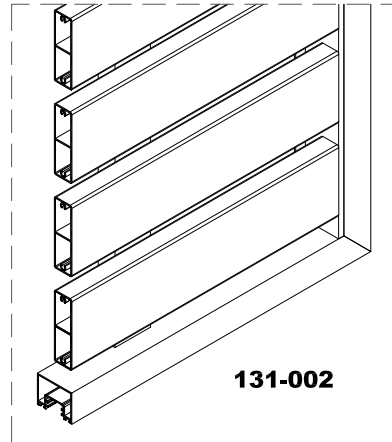
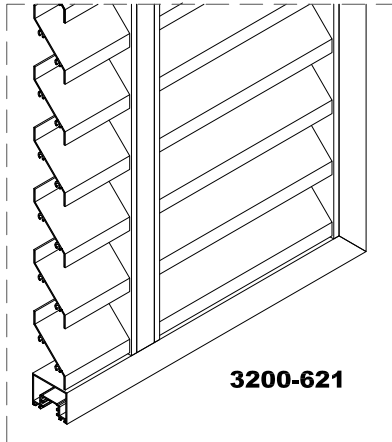



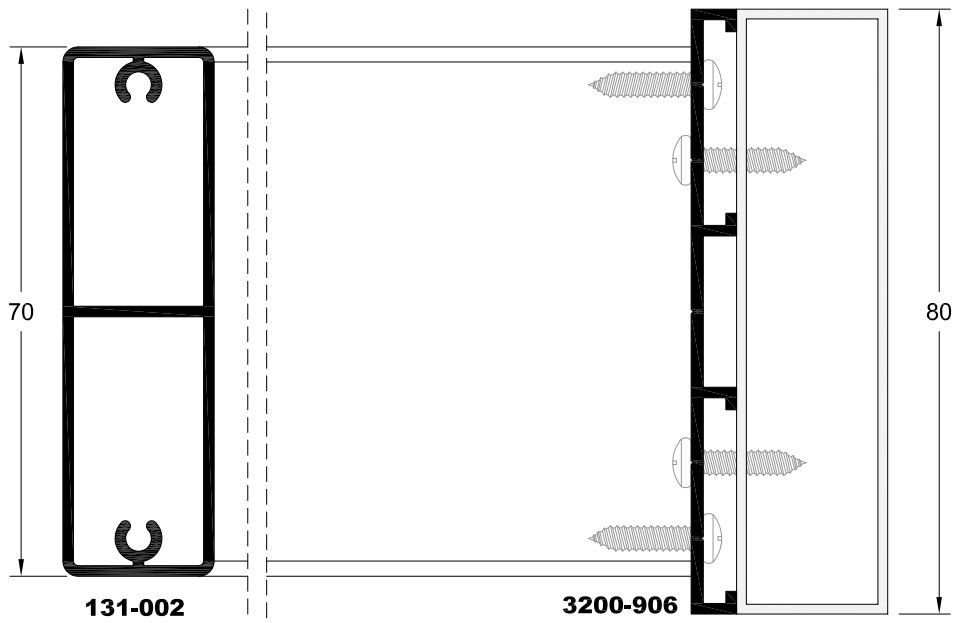
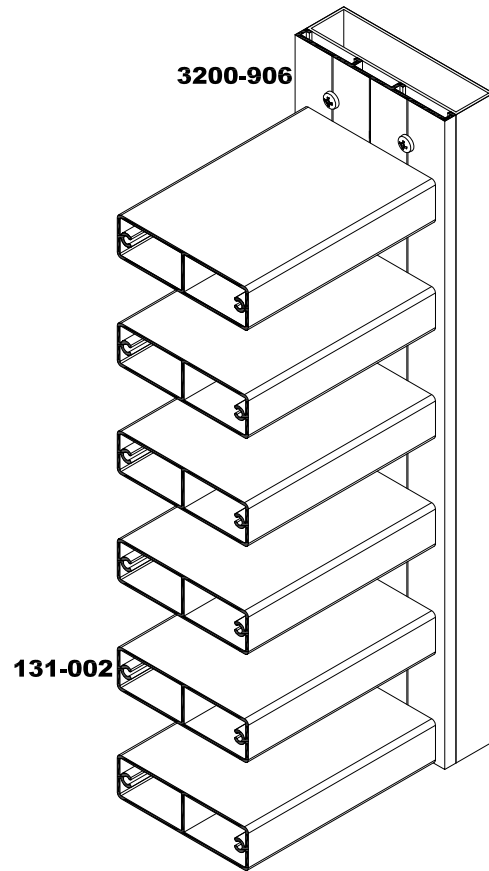

**FIXED LOUVER ASSEMBLY**  
**INSTALLATION DE PERSIENNE FIXE**



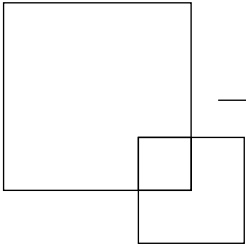

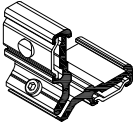
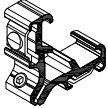

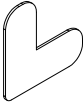
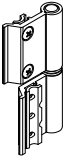
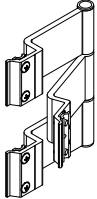

**SH 3200**  
ALUMINIUM SYSTEMS

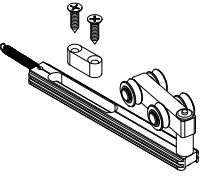
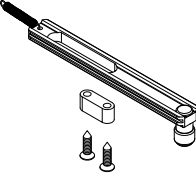
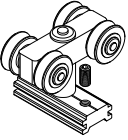
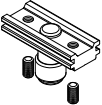
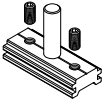
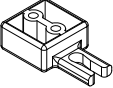
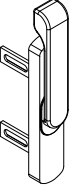
Accessories  
Accessoires



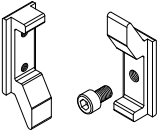

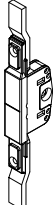
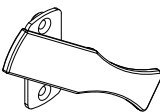

	<p>Code   Code:</p> <p><b>EA410-124U</b></p>	<p><b>Description: CORNER JOINT 35.5x14mm</b>                  Description: DESCRIPTION ANGLES DE CONNEXION 35.5x14mm</p> <p><b>(For profile: 3200-201, 3200-202)</b>                  (Pour profil: 3200-201, 3200-202)</p> <p>Package   Paquet: <b>100 pcs/article</b></p>
	<p>Code   Code:</p> <p><b>EA450-137U</b></p>	<p><b>Description: CORNER JOINT 19.2x18.2mm</b>                  Description: DESCRIPTION ANGLES DE CONNEXION 19.2x18.2mm</p> <p><b>(For profile: 3200-908)</b>                  (Pour profil: 3200-908)</p> <p>Package   Paquet: <b>100 pcs/article</b></p>
	<p>Code   Code:</p> <p><b>EA510-207I/U</b></p>	<p><b>Description: ALIGNMENT CORNER 7mm</b>                  Description: COIN ALIGNMENT 7mm</p> <p><b>I= Inox</b>  <b>U= Galvanized</b></p> <p>Package   Paquet: <b>5000 pcs/article</b></p>
	<p>Code   Code:</p> <p><b>EA410-216I/U</b></p>	<p><b>Description: ALIGNMENT CORNER 16mm</b>                  Description: COIN ALIGNMENT 16mm</p> <p><b>I= Inox</b>  <b>U= Galvanized</b></p> <p>Package   Paquet: <b>2000 pcs/article</b></p>
	<p>Code   Code:</p> <p><b>E3200-320</b></p>	<p><b>Description: HINGE FOR OPENING</b>                  Description: CHARNIÈRE DE OUVERTURE</p> <p>Package   Paquet: <b>100 pcs/article</b></p>
	<p>Code   Code:</p> <p><b>E3200-330</b></p>	<p><b>Description: LONG HINGE</b>                  Description: CHARNIÈRE DE OUVERTURE</p> <p>Package   Paquet: <b>30 pcs/article</b></p>
	<p>Code   Code:</p> <p><b>E3200-322</b></p>	<p><b>Description: HINGE FOR FOLDING</b>                  Description: CHARNIÈRE ACCORDEON</p> <p>Package   Paquet: <b>100 pcs/article</b></p>

	<p>Code   Code:</p> <p><b>E3200-342</b></p>	<p><b>Description: TOP ROLLER FOR FOLDING SYSTEM</b> Description: ROULEAU SUPÉRIEU DU SYSTEME DE ACCORDEON</p> <p>Package   Paquet: 1 pc/article</p>
	<p>Code   Code:</p> <p><b>E3200-352</b></p>	<p><b>Description: BOTTOM ROLLER FOR FOLDING SYSTEM</b> Description: ROULEAU INFÉRIEUR DU SYSTEME DE ACCORDEON</p> <p>Package   Paquet: 1 pc/article</p>
	<p>Code   Code:</p> <p><b>E3200-343</b></p>	<p><b>Description: TOP ROLLER FOR SLIDING</b> Description: ROULEAU SUPÉRIEUR DU SYSTEME DE ACCORDEON</p> <p>Package   Paquet: 1 pc/article</p>
	<p>Code   Code:</p> <p><b>E3200-311</b></p>	<p><b>Description: BOTTOM ROLLER FOR SLIDING</b> Description: ROULEAU INFÉRIEUR</p> <p>Package   Paquet: 1 pc/article</p>
	<p>Code   Code:</p> <p><b>E3200-393</b></p>	<p><b>Description: STOP FOR SLIDING SASH</b> Description: BUTÉE DE FIN POUR COULISSANT</p> <p>Package   Paquet: 1 pc/article</p>
	<p>Code   Code:</p> <p><b>E3200-831</b></p>	<p><b>Description: STOP ON RAIL FOR SLIDING SASH</b> Description: BUTÉE DE FIN POUR TRAVERSE DE COULISSANT</p> <p>Package   Paquet: 20 pcs/article</p>
	<p>Code   Code:</p> <p><b>E3200-571</b></p>	<p><b>Description: CREMONE BOLT FOR EXTERNAL OPENING</b> Description: CREMONE BI-DIRECTIONNEL</p> <p>Package   Paquet: 20 pcs/article</p>

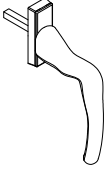
	<p>Code   Code:</p> <p><b>E3200-562</b></p>	<p><b>Description: ADDITIONAL PARTS FOR ROD (MASTER)</b>                  Description: ACCESSOIRES DE BARRE DE VERROUILLAGE (MASTER)</p> <p><b>Package   Paquet: 20 pcs/article</b></p>
	<p>Code   Code:</p> <p><b>E3200-561</b></p>	<p><b>Description: HOOKS FOR LOCKING</b>                  Description: CROCHET DE VERROUILLAGE</p> <p><b>Package   Paquet: 50 pcs/article</b></p>
	<p>Κωδικός   Code:</p> <p><b>UO140.7MA</b></p>	<p><b>Περιγραφή: ADJUSTABLE LOCK MECHANISM WITH SQUARE (MASTER)</b>                  Description: SERRURE RÉGLABLE AVEC CARRE (MASTER)</p> <p><b>Package   Paquet: 10 pcs/article</b></p>
	<p>Κωδικός   Code:</p> <p><b>UO140.7SI</b></p>	<p><b>Περιγραφή: ADJUSTABLE LOCK MECHANISM WITH SQUARE (SIEGENIA LM-40)</b>                  Description: SERRURE RÉGLABLE AVEC CARRE (SIEGENIA LM-40)</p> <p><b>Package   Paquet: 10 pcs/article</b></p>
	<p>Code   Code:</p> <p><b>US730.2SIX</b>  <b>US730.2SIA</b></p>	<p><b>Description: HANDLE WITH SQUARE PIN SIEGENIA</b>                  Description: POIGNÉE AU CARRE SIEGENIA</p> <p><b>X= BLACK/NOIRE</b>  <b>A=WHITE/BLANC</b></p> <p><b>Package   Paquet: 100 pcs/article</b></p>
	<p>Code   Code:</p> <p><b>US230-1MA</b></p>	<p><b>Description: LOCK WITH SPINNING HANDLE MASTER</b>                  Description: SERRURE AVEC POIGNÉE SPINING MASTER</p> <p><b>Package   Paquet: 20 pcs/article</b></p>
	<p>Code   Code:</p> <p><b>US230-3MA</b></p>	<p><b>Description: HANDLE FOR SLIDING</b>                  Description: POIGNÉE POUR SERRURE DE COULISSANT</p> <p><b>Package   Paquet: 20 pcs/article</b></p>

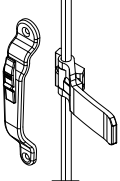
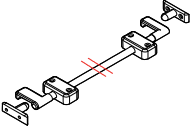
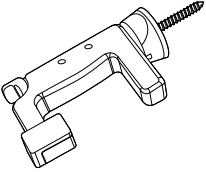
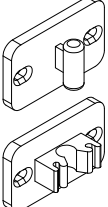

	<p>Code   Code:</p> <p><b>E3200-521</b></p>	<p><b>Description: HANDLE WITH SQUARE PIN GIESSE</b> Description: POIGNÉE AU CARRE GIESSE</p> <p><b>Package   Paquet: 5 pcs/article</b></p>									
	<p>Code   Code:</p> <p><b>US712-1RTMR</b> (right black / droit noir) <b>US712-1RTML</b> (left black / gauche noir)</p>	<p><b>Description: HANDLE WITH SQUARE PIN HOPPE</b> Description: POIGNÉE AU CARRE HOPPE</p> <p><b>Package   Paquet: 1 τεμ./pc</b></p>									
	<p>Code   Code:</p> <p><b>E3200-392</b></p>	<p><b>Description: PIN FOR LOCKING OF FOLDING SYSTEM</b> Description: GOUPILLE DE VEROUILLAGE</p> <p><b>Package   Paquet: 1 pair./paire</b></p>									
	<p>Code   Code:</p> <p><b>UO864-1PLM</b></p>	<p><b>Description: SHUTTERS LOCK, BLACK</b> Description: SERRURE DE VANTAUX</p> <p><b>Package   Paquet: 50 pcs/article</b></p>									
	<p>Κωδικός   Code:</p> <p>(A) <b>UO865-1PLM</b> (B) <b>UO865-2PLM</b></p>	<p><b>Description: SHUTTER ROD FOR UO864-1PLM</b> Description: BARRE POUR UO864-1PLM</p> <table border="1" data-bbox="810 1378 1299 1480"> <thead> <tr> <th></th> <th>Dimenslons - Dimensions</th> <th>Package - Paquete</th> </tr> </thead> <tbody> <tr> <td>(A)</td> <td><b>140 mm</b></td> <td><b>10 pcs/article</b></td> </tr> <tr> <td>(B)</td> <td><b>230 mm</b></td> <td><b>10 pcs/article</b></td> </tr> </tbody> </table>		Dimenslons - Dimensions	Package - Paquete	(A)	<b>140 mm</b>	<b>10 pcs/article</b>	(B)	<b>230 mm</b>	<b>10 pcs/article</b>
	Dimenslons - Dimensions	Package - Paquete									
(A)	<b>140 mm</b>	<b>10 pcs/article</b>									
(B)	<b>230 mm</b>	<b>10 pcs/article</b>									
	<p>Code   Code:</p> <p><b>UO861-1ALM</b></p>	<p><b>Description: PLASTIC HOLDER FOR SHUTTERS</b> Description: SUPPORT EN PLASTIQUE POUR VANTAUX</p> <p><b>Package   Paquet: 20 pcs/article</b></p>									
	<p>Code   Code:</p> <p><b>E3200-563</b></p>	<p><b>Description: SASHES HOLDER FOR FOLDING SYSTEM</b> Description: SUPPORT DE SYSTÈME PLIANTE</p> <p><b>Package   Paquet: 20 pcs/article</b></p>									

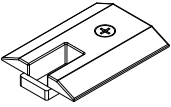
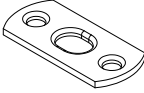
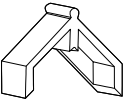
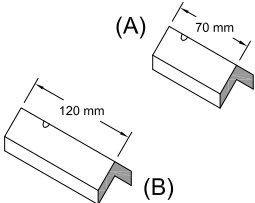
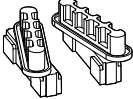
	<p>Code   Code:</p> <p><b>E3200-381</b></p>	<p><b>Description: PLASTIC LATCH KIT FOR OPENING LOCKING</b>                  Description: TARGET EN PLASTIQUE DE SYSTÈME OUVRANT</p> <p><b>Package   Paquet: 20 pcs/article</b></p>
	<p>Code   Code:</p> <p><b>E3200-382</b></p>	<p><b>Description: PLASTIC LATCH KIT FOR SECOND SASH</b>                  Description: TARGET EN PLASTIQUE DE SYSTÈME A DEUX VANTAUX</p> <p><b>Package   Paquet: 20 pcs/article</b></p>
	<p>Code   Code:</p> <p><b>E3200-391</b></p>	<p><b>Description: LATCH STRIKER FOR OPENINGS</b>                  Description: VERROU DE SYSTÈME</p> <p><b>Package   Paquet: 20 pcs/article</b></p>
	<p>Code   Code:</p> <p><b>EA410-587</b></p>	<p><b>Description: METALLIC LATCH STRIKER</b>                  Description: SUPPORT DE TRAVERSE</p> <p><b>Package   Paquet: 10 pcs/article</b></p>
	<p>Code   Code:</p> <p><b>EA410-846M</b></p>	<p><b>Description: SPACER FOR 245-013 SHUTTER PROFILE</b>                  Description: ENTRETOISE PERSIENNE</p> <p><b>Package   Paquet: 600 pcs/article</b></p>
	<p>Code   Code:</p> <p>(A) <b>EA410-847M</b></p> <p>(B) <b>EA410-848M</b></p>	<p><b>Description: SPACER 70mm FOR 245-013 SHUTTER PROFILE</b>                  Description: SPACER 70mm FOR 245-013 SHUTTER PROFILE</p> <p><b>Description: SPACER 120mm FOR 245-013 SHUTTER PROFILE</b>                  Description: SPACER 120mm FOR 245-013 SHUTTER PROFILE</p> <p><b>Package   Paquet: 1 τεμ./pc</b></p>
	<p>Code   Code:</p> <p><b>EA540-831M</b></p>	<p><b>Description: END COVER FOR PROFILE 38-006</b>                  Description: COUVERCLE POUR PROFIL 38-006</p> <p><b>Package   Paquet: 500 pcs/article</b></p>

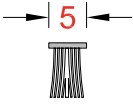
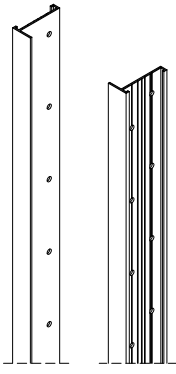
	<p>Code   Code:</p> <p><b>EA410-412</b></p>	<p><b>Description:</b> GASKET WEATHERSTRIPES FOAM FOR SHUTTER Description: GASKET WEATHERSTRIPES FOAM FOR SHUTTER</p> <p><b>Package   Paquet:</b> 200 m</p>
	<p>Code   Code:</p> <p><b>US506-2FSM</b> <b>US510-2FSM</b> <b>US512-2FSM</b></p>	<p><b>Περιγραφή:</b> BRUSH BLACK (BASE 5mm) Description: BROSSE NOIR (BASE 5mm)</p> <p><b>Package   Paquet:</b> 325 m <b>Package   Paquet:</b> 400 m <b>Package   Paquet:</b> 300 m</p>
	<p>Code   Code:</p> <p><b>E3200-751</b></p> <p><b>E3200-752</b></p> <p><b>E3200-753</b></p>	<p><b>Description:</b> BAR FOR PROFILE SH3200-621 (3m) Description: SYSTÈME DE BARRE POUR PROFIL SH3200-621 (3m)</p> <p><b>Description:</b> BAR FOR PROFILE SH3200-622 &amp; 623 (3m) Description: SYSTÈME DE BARRE POUR PROFIL SH3200-622 &amp; 623 (3m)</p> <p><b>Description:</b> BAR FOR PROFILE SH3200-624 (3m) Description: SYSTÈME DE BARRE POUR PROFIL SH3200-624 (3m)</p> <p><b>Package   Paquet:</b> 1 pair./paire</p>

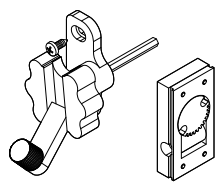
	<p>Code   Code:</p> <p><b>EA540-771/01</b></p>	<p><b>Description: ROTOR (For 25mm) FOR MOVING LEVER</b>                  Description: ROTOR POUR PERSIENNE MOVABLE (25mm)</p> <p>Package   Paquet: <b>50 pcs/article</b></p>
---	--	---

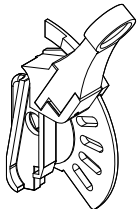
	<p>Code   Code:</p> <p><b>EA540-772/R</b> <b>EA540-772/L</b></p>	<p><b>Description: LEVER FOR MOVING LEVER</b>                  Description: POIGNEE POUR PERSIENNE MOVABLE</p> <p>Package   Paquet: <b>50 pcs/article</b></p>
---	--	---

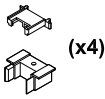
	<p>Code   Code:</p> <p><b>EA540-773/01</b></p>	<p><b>Description: PLASTIC CAPS (For 25mm)</b>                  Description: Description Plastique supplémentaire et finition (Pour25mm)</p> <p>Package   Paquet: <b>50 pcs/article</b></p>
---	--	---

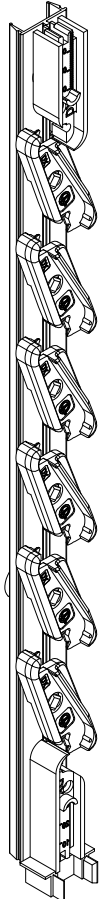
 <p><b>Pair</b> <b>Paire</b></p>	<p>Code   Code:</p> <table border="0"> <tr> <td><b>EA540-706/01</b></td> <td>6</td> </tr> <tr> <td><b>EA540-707/01</b></td> <td>7</td> </tr> <tr> <td><b>EA540-708/01</b></td> <td>8</td> </tr> <tr> <td><b>EA540-709/01</b></td> <td>9</td> </tr> <tr> <td><b>EA540-710/01</b></td> <td>10</td> </tr> <tr> <td><b>EA540-711/01</b></td> <td>11</td> </tr> <tr> <td><b>EA540-712/01</b></td> <td>12</td> </tr> <tr> <td><b>EA540-713/01</b></td> <td>13</td> </tr> <tr> <td><b>EA540-714/01</b></td> <td>14</td> </tr> <tr> <td><b>EA540-715/01</b></td> <td>15</td> </tr> <tr> <td><b>EA540-716/01</b></td> <td>16</td> </tr> <tr> <td><b>EA540-717/01</b></td> <td>17</td> </tr> <tr> <td><b>EA540-718/01</b></td> <td>18</td> </tr> <tr> <td><b>EA540-719/01</b></td> <td>19</td> </tr> <tr> <td><b>EA540-720/01</b></td> <td>20</td> </tr> <tr> <td><b>EA540-721/01</b></td> <td>21</td> </tr> <tr> <td><b>EA540-722/01</b></td> <td>22</td> </tr> <tr> <td><b>EA540-723/01</b></td> <td>23</td> </tr> <tr> <td><b>EA540-724/01</b></td> <td>24</td> </tr> <tr> <td><b>EA540-725/01</b></td> <td>25</td> </tr> <tr> <td><b>EA540-726/01</b></td> <td>26</td> </tr> <tr> <td><b>EA540-727/01</b></td> <td>27</td> </tr> <tr> <td><b>EA540-728/01</b></td> <td>28</td> </tr> <tr> <td><b>EA540-729/01</b></td> <td>29</td> </tr> <tr> <td><b>EA540-730/01</b></td> <td>30</td> </tr> <tr> <td><b>EA540-731/01</b></td> <td>31</td> </tr> <tr> <td><b>EA540-732/01</b></td> <td>32</td> </tr> </table>	<b>EA540-706/01</b>	6	<b>EA540-707/01</b>	7	<b>EA540-708/01</b>	8	<b>EA540-709/01</b>	9	<b>EA540-710/01</b>	10	<b>EA540-711/01</b>	11	<b>EA540-712/01</b>	12	<b>EA540-713/01</b>	13	<b>EA540-714/01</b>	14	<b>EA540-715/01</b>	15	<b>EA540-716/01</b>	16	<b>EA540-717/01</b>	17	<b>EA540-718/01</b>	18	<b>EA540-719/01</b>	19	<b>EA540-720/01</b>	20	<b>EA540-721/01</b>	21	<b>EA540-722/01</b>	22	<b>EA540-723/01</b>	23	<b>EA540-724/01</b>	24	<b>EA540-725/01</b>	25	<b>EA540-726/01</b>	26	<b>EA540-727/01</b>	27	<b>EA540-728/01</b>	28	<b>EA540-729/01</b>	29	<b>EA540-730/01</b>	30	<b>EA540-731/01</b>	31	<b>EA540-732/01</b>	32	<p><b>Description: BAR SYSTEM (BLACK)</b>                  Description: SYSTEME DE BARRE (NOIR)</p> <p>Package   Paquet: <b>10 pcs/article</b></p>
	<b>EA540-706/01</b>	6																																																						
<b>EA540-707/01</b>	7																																																							
<b>EA540-708/01</b>	8																																																							
<b>EA540-709/01</b>	9																																																							
<b>EA540-710/01</b>	10																																																							
<b>EA540-711/01</b>	11																																																							
<b>EA540-712/01</b>	12																																																							
<b>EA540-713/01</b>	13																																																							
<b>EA540-714/01</b>	14																																																							
<b>EA540-715/01</b>	15																																																							
<b>EA540-716/01</b>	16																																																							
<b>EA540-717/01</b>	17																																																							
<b>EA540-718/01</b>	18																																																							
<b>EA540-719/01</b>	19																																																							
<b>EA540-720/01</b>	20																																																							
<b>EA540-721/01</b>	21																																																							
<b>EA540-722/01</b>	22																																																							
<b>EA540-723/01</b>	23																																																							
<b>EA540-724/01</b>	24																																																							
<b>EA540-725/01</b>	25																																																							
<b>EA540-726/01</b>	26																																																							
<b>EA540-727/01</b>	27																																																							
<b>EA540-728/01</b>	28																																																							
<b>EA540-729/01</b>	29																																																							
<b>EA540-730/01</b>	30																																																							
<b>EA540-731/01</b>	31																																																							
<b>EA540-732/01</b>	32																																																							
<p>Number of louvers Numero des persiennes</p>																																																								

## INSTRUCTIONS FOR THE CONSTRUCTION OF FRAMES

- Fabricator should always have all the necessary technical documentation, manuals and catalogs of systems that describe all the details of any type of construction.
- Fabricator should be aware of the possibilities of profiles in order to provide the appropriate solutions for each case at the client.
- Fabricator should have all the necessary tools and machinery in order to produce high quality products.
- Milling and machining on profiles must be executed with absolute precision based on the instructions of the technical manuals.
- At the cutting points (piercing) of profiles is necessary to use protective materials (Bourgal), to avoid the appearance of electrolysis.
- At the assembly of profiles is necessary to use sealant (polyurethane adhesive) in order to seal the profiles from any water inflows and air.
- Fabricator should always use all the necessary accessories and mechanisms recommended by the company to ensure the quality and proper functionality of the frames.
- At the construction and installation of the frames, screws should be of stainless steel or galvanized to prevent corrosion.
- Fabricator should open all the necessary weep holes in a frame for runoff water. The number of weep holes depend on the orientation and dimensions of the frame. (See technical manual).
- Fabricator should use cyanoacrylate glue to the contact points of gasket.
- Fabricator must properly support (shims application) the glazing, with plastic shims, at the projected points for the proper function of the frame. (See technical manual).
- Fabricator should select and place subframe depending on the typology of each frame for the proper support of the frame.
- Fabricator should estimate a perimeter joint between the frame and sub-frame of 2,5-3mm for non-thermal break systems and 5-6mm for thermal break systems.
- Fabricator must choose the correct sealing materials during installation. More specifically:
  1. We place neutral silicone or polyurethane sealant at the bottom, inner and outer of the frame, between frame and sill.
  2. We place acrylic putty both sides and on the top inner and outer of the frame, between the frame and the wall. Painting in acrylic putty is necessary.

**Attention:** The surfaces (frame, sill & wall) must be clean and dry for the effective adhesion of insulating materials.

**For any questions on technical matters, contact the technical department of the company.**

## INSTRUCTIONS FOR PROTECTION & MAINTENANCE OF FRAMES

Aluminium systems are characterized by high resistance to weather conditions and time.

To ensure and maintain good function and timeless beauty, it is necessary to follow the simple but basic below rules for proper maintenance and cleaning:

- Aluminium profiles must be cleaned at regular basis.
- In industrial or coastal areas, cleaning must be done more often and with great meticulousness.
- At the time of cleaning is recommended to use water and cleaners with a neutral pH.
- Alkaline materials such as cement, lime and plaster should not remain, at any time, on the aluminium surface.
- Immediately after the installation of frames, the protective film must be removed from the surface of aluminium, where its exposure to sunlight may cause a serious damage.
- The moving parts, mechanisms and gaskets should be cleaned and lubricated with silicone spray periodically.
- In any case, a full maintenance control of aluminium systems - once a year - is necessary from a professional fabricator.

## INSTRUCTIONS POUR LA CONSTRUCTION DES PANNEAUX

- Le menuisier doit connaître toute la gamme de profilés ainsi que leur utilité/options.
- Il doit répondre aux contraintes et proposer la construction adéquate à chaque cas.
- Il doit fabriquer et poser le dormant adéquat à chaque châssis.
- Il doit calculer l'espace entre le dormant et le châssis, de 2.5 à 3mm de chaque côté (tenant en compte le joint circconférentiel de pont thermique), afin de mieux poser et mieux ajuster le châssis. De plus, il peut atteindre une meilleure isolation thermique en injectant de la colle à l'espace entre le châssis et le dormant (au lieu de l'injecter uniquement sur la surface).
- Il doit découper et unir correctement les châssis mais aussi protéger les points de jonction à l'aide de produits d'anti-corrosion.
- Il doit injecter de la colle sur les points de jonction de profils pour optimiser le drainage.
- Il doit Injecter de la silicone sur la partie basse du châssis, entre le châssis et le marbre, afin d'empêcher l'entrée d'eau à l'intérieur du bâtiment.
- Il doit prévoir les éviers nécessaires dépendant de l'endroit où le châssis est posé.
- Il prévoir des puits pour évacuer les eaux qui croupissent a la partie basse de voles et éviter la corrosion.
- Utiliser les accessoires présentés dans les catalogues.
- Demander toujours de joints d'étanchéité EPDM
- Tasser bien les vitrages pour que les vantaux soient bien stables.
- Demander l'aide de techniciens quand il s'agit de constructions compliquées afin d'éviter les contraintes.

### Note:

Les joints doivent toujours se boutonner (non pas se coller dessus) sur les châssis afin de faciliter leur remplacement.

## INSTRUCTIONS POUR LA MAINTENANCE DES PANNEAUX

- Le nettoyage fréquent de profilés maintiendra la peinture en bonnes conditions
- Le nettoyage est nécessaire quand il y a de la poussière ou d'autre impuretés sur les profilés (PH 5 - 5.8)
- Le nettoyage occasionnel doit se faire avec une éponge et de l'eau contenant un facteur anticorrosion neutre. Ensuite on rince.
- Les produits de nettoyage ne doivent pas infecter les profilés (pas déponge dure, paille de fer ou d'autres produits dissolvants). Un facteur important est aussi la région/l'endroit où le bâtiment est construit.
- Spécialement aux régions maritimes (bord de la mer) où des zones industrielles le nettoyage doit être fréquent. De matériaux de construction tels que du ciment, de la chaux ou du plâtre ne doivent pas rester sur les profilés
- Aussi on doit éviter de rubans adhésifs sur la peinture.
- Le film de protection posé à l'usine est bon pour usage. Attention, il doit impérativement être enlevé après la pose du châssis car son exposition au soleil peut générer de problèmes sur la peinture.

**Le respect de tous les points ci-dessus ainsi que l'usage de colle spéciale aux points où la peinture est détruite (à cause du découpage de profilés), conservera l'aspect initial de la peinture et protégera d'une probable corrosion.**

# Available aluminium systems

## Systemes en aluminium disponibles



**AL 200**



**AL 205**



**AL 220**



**AL 230**

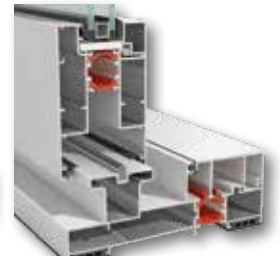

**AL 250**



**AL 410**



**AL 450**



**AL 510**

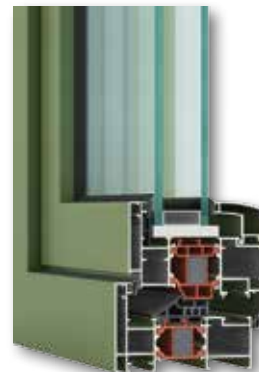

**AL 570  
Dynamic Plus**



**AL 570  
Dynamic**

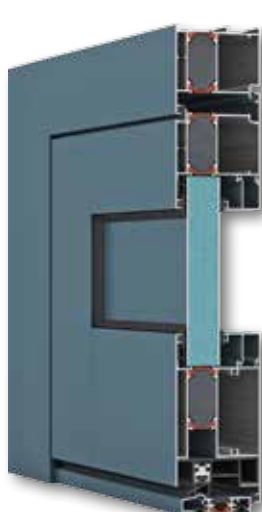

**AL 590**  
24mm Polyamide



**AL 590**  
16mm Polyamide



**EW 50**  
Curtain Wall



**SR 750**  
Rolling Shutter

## General Information

- This catalog has been compiled with the greatest of care. The company cannot be responsible for any technical, printing or spelling errors that may occur.
- **The latest version of this catalog is available at the official website of the company.**
- The company has a full range of catalogs for all products. Order or download free the catalog you are interested in from the official website [aluminco.com](http://aluminco.com).
- Register now to [aluminco.com](http://aluminco.com) and find the latest news, new applications and studies of ALUMINCO.

## Informations generales

- Ce catalogue a été rédigé avec le plus grand soin. L'entreprise n' est pas responsable de fautes de l' orthographe ou d' impression.
- **La dernière Edition de ce catalogue existe sur notre site internet.**
- La société dispose de catalogues techniques pour l' ensemble de systèmes et produits.
- Inscrivez-vous au [www.aluminco.com](http://www.aluminco.com) pour télécharger nos catalogues, tarifs, newsletter et nouveau réalisations.



The date of issue of this catalog is written at the back cover.  
La date de délivrance de ce catalogue est écrit à la couverture arrière.



---

Shutter system



03/2016

Aluminium Building Systems Industry - 320 11 Inofita Viotia - Greece  
tel. +30 22620 47000 - fax +30 22620 47090 - [info@aluminco.com](mailto:info@aluminco.com), [exports@aluminco.com](mailto:exports@aluminco.com)